

**SOLE**  
FITNESS

**OWNER'S MANUAL**

**Model: 16208960940**

*Please carefully read this entire manual  
before operating your new bike.*

**ATTENTION:** *Before returning your Sole product to any retailer, or if you require any assistance with assembly or technical support please call us first for assistance at 1-888-707-1880. Thank you for your Sole purchase.*

# TABLE OF CONTENTS

<u>Product Registration</u>	<b>2</b>
<u>Important Safety Instructions</u>	<b>3</b>
<u>Important Electrical Information</u>	<b>4</b>
<u>Important Operation Instructions</u>	<b>4</b>
<u>B94 Assembly Instructions</u>	<b>6</b>
<u>Fitness Bike Features</u>	<b>10</b>
<u>Operation of Your New Fitness Bike</u>	<b>11</b>
<u>Bluetooth® Connectivity</u>	<b>14</b>
<u>Programmable Features</u>	<b>17</b>
<u>Using Heart Rate Monitor</u>	<b>22</b>
<u>General Maintenance</u>	<b>24</b>
<u>B94 Exploded View Diagram</u>	<b>25</b>
<u>B94 Parts List</u>	<b>26</b>
<u>Manufacturer's Limited Warranty</u>	<b>29</b>

## ATTENTION

THIS FITNESS BIKE IS INTENDED FOR RESIDENTIAL USE ONLY AND IS WARRANTED FOR THE APPLICATION. ANY OTHER APPLICATION VOIDS THIS WARRANTY IN ITS ENTIRETY.

Ver. F

# SOLE

## FITNESS

CONGRATULATIONS ON YOUR NEW BIKE, AND WELCOME TO THE SOLE FAMILY!

Thank you for your purchase of this quality Sole bike from Dyaco Canada Inc. Your new bike has been manufactured by one of the leading fitness manufacturers in the world and is backed by one of the most comprehensive warranties available. Dyaco Canada Inc. will do all we can to make your ownership experience as pleasant as possible for many years to come.

If you have any questions about your new Sole product or questions about the warranty, contact Dyaco Canada Inc. at 1-888-707-1880.

Please take a moment at this time to record below the name of the dealer, their telephone number, and the date of purchase for easy contact in the future. We appreciate your confidence in SOLE, and we will always remember that you are the reason that we are in business. Please go to [www.dyaco.ca/warranty.html](http://www.dyaco.ca/warranty.html) and complete the online warranty registration.

Yours in Health,  
Dyaco Canada Inc.

Name of Dealer \_\_\_\_\_

Telephone Number of Dealer \_\_\_\_\_

Purchase Date \_\_\_\_\_

## PRODUCT REGISTRATION

RECORD YOUR SERIAL NUMBER

Please record the Serial Number of this fitness product in the space provided below.

Serial Number \_\_\_\_\_



Register your purchase

Please visit us at [www.dyaco.ca/warranty.html](http://www.dyaco.ca/warranty.html) to register your purchase.

# IMPORTANT SAFETY INSTRUCTIONS

**WARNING** - Read all instructions before using this appliance.

- Do not operate fitness bike on deeply padded, plush or shag carpet. Damage to both carpet and fitness bike may result.
- Keep children under the age of 13 away from this machine. There are obvious pinch points and other caution areas that can cause harm.
- Keep hands away from all moving parts.
- Never operate the fitness bike if it has a damaged cord or plug. If the fitness bike is not working properly, call your dealer.
- Keep the cord away from heated surfaces.
- Never drop or insert any object into any openings.
- Do not use outdoors.
- To disconnect, turn all controls to the off position, remove tether cord, then remove the plug from the outlet.
- Do not attempt to use your fitness bike for any purpose other than for the purpose it is intended.
- The hand pulse sensors are not medical devices. Various factors, including the user's movement, may affect the accuracy of heart rate readings. The pulse sensors are intended only as exercise aids in determining heart rate trends in general.
- Wear proper shoes. High heels, dress shoes, sandals or bare feet are not suitable for use on your fitness bike. Quality athletic shoes are recommended to avoid leg fatigue or injury.
- This appliance is not intended for use by persons with reduced physical, sensory or mental capabilities or lack of experience and knowledge unless they have been given supervision or instruction concerning use of the appliance by a person responsible for their safety.

**SAVE THESE INSTRUCTIONS - THINK SAFETY!**

# IMPORTANT ELECTRICAL INSTRUCTIONS

## **WARNING!**

**NEVER** remove any cover without first disconnecting AC power.

If voltage varies by ten percent (10%) or more, the performance of your fitness bike may be affected. Such conditions are not covered under your warranty. If you suspect the voltage is low, contact your local power company or a licensed electrician for proper testing.

**NEVER** expose this fitness bike to rain or moisture. This product is NOT designed for use outdoors, near a pool or spa, or in any other high humidity environment. The operating temperature specification is 40 to 120 degrees Fahrenheit, and humidity is 95% non-condensing (no water drops forming on surfaces).

# IMPORTANT OPERATION INSTRUCTIONS

**NEVER** operate this fitness bike without reading and completely understanding the results of any operational change you request from the computer.

**NEVER** use your fitness bike during an electrical storm. Surges may occur in your household power supply that could damage fitness bike components. Unplug the fitness bike during an electrical storm as a precaution.

Do not use excessive pressure on console control keys. They are precision set to function properly with little finger pressure. If you feel the buttons are not functioning properly with normal pressure, contact your SOLE dealer.

# B94 ASSEMBLY PACK CHECKLIST

Note: The hardware could be found on the cycle or found in the hardware bag for each step.

## 1 HARDWARE STEP 1

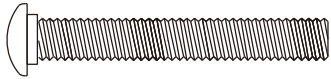

#50. 3/8"×53L  
Carriage Bolt (2 pcs)



#135. 3/8" ×16 × 12.5T\_  
Cap Nut (2 pcs)

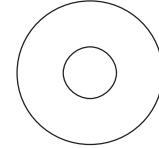

#71. 3/8" x 25 x 2T  
Flat Washer (2 pcs)

## 2 HARDWARE STEP 2

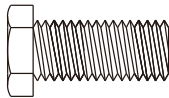

#51. 5/16" x 5/8"  
Hex Head Bolt (7 pcs)

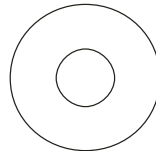

#72. 5/16" x 18 x 1.5T  
Flat Washer (6 pcs)

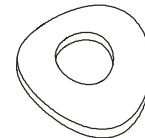

#99. 5/16" x 19 x 1.5T  
Curved Washer (1 pc)

## 3 HARDWARE STEP 3

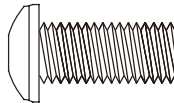

#74. 5/16" x 5/8"  
Button Head Socket  
Bolt (4 pcs)

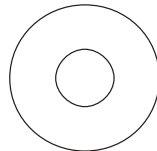

#72. 5/16" x 18 x 1.5T  
Flat Washer (4 pcs)



#103. 5/16" x 1.5T  
Split Washer (4 pcs)

## 4 HARDWARE STEP 4

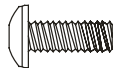

#58. M5 x 12mm  
Phillips Head Screw (6 pcs)

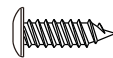

#161. 3.5 × 12L\_  
Sheet Metal Screw (4 pcs)

# ASSEMBLY TOOLS

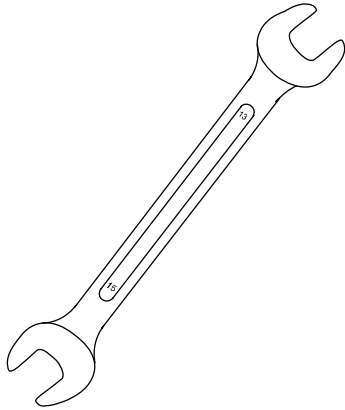

**#92.** 13/15mm Wrench

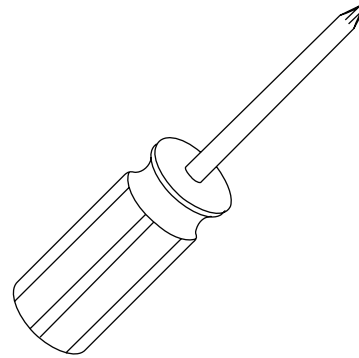

**#93.** Phillips Head Screwdriver

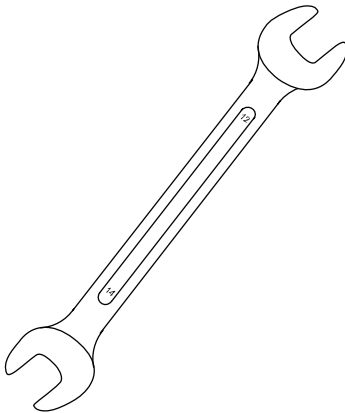

**#100.** 12/14mm Wrench

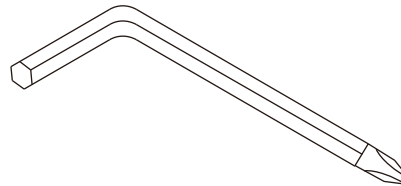

**#76.** Combination M5 Allen Wrench & Phillips Head Screw Driver

# B94 ASSEMBLY INSTRUCTIONS

## PRE-ASSEMBLY

1. Using a razor knife (Box Cutter), cut the outside, bottom, edge of the box along the dotted line. Lift Box over the unit and unpack.
2. Carefully remove all parts from the carton and inspect for any damage or missing parts. If damaged parts are found or parts are missing, contact your dealer immediately.
3. Locate the hardware package. Remove the tools first. Remove the hardware for each step as needed to avoid confusion. The numbers in the instructions that are in parenthesis (#) are the item number from the assembly drawing for reference.
4. The hardware could be found on the cycle or found in the hardware bag for each step.

# 1 REAR STABILIZER

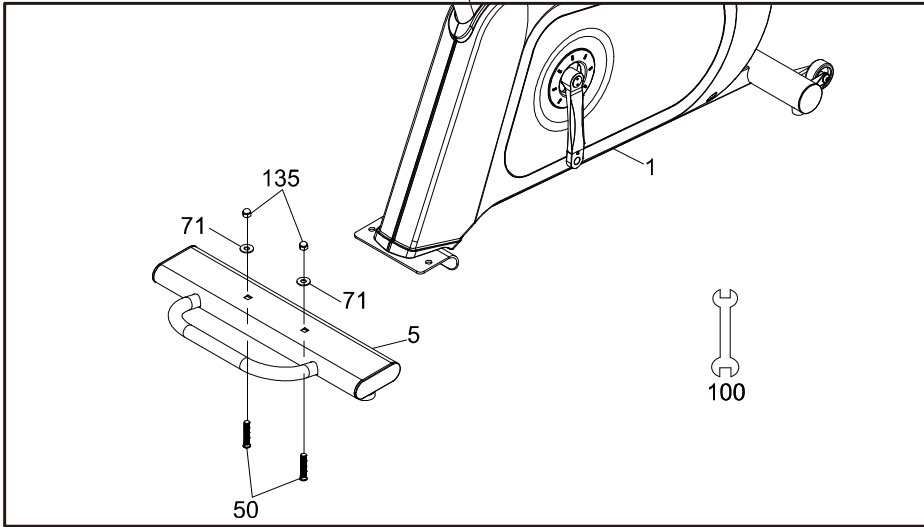

## HARDWARE STEP 1

#50. 3/8" x 53L  
Carriage Bolt (2 pcs)  
#135. 3/8" x 16 x 12.5T\_  
Cap Nut (2 pcs)  
#71. 3/8" x 25 x 2T  
Flat Washer (2 pcs)

1. Attach the Rear Stabilizer (5) to the Main Frame (1) by sliding two Cap Nuts (135), two Flat Washers (71) onto two Carriage Bolt (50), then into the rear stabilizer. Tighten using the 12/14 mm Wrench (100).

# 2 CONSOLE MAST

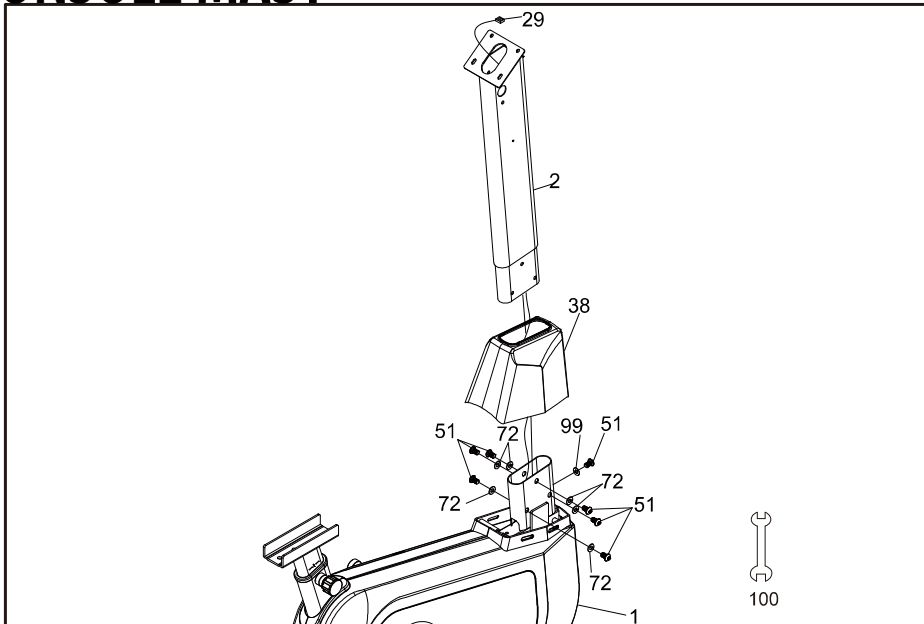

## HARDWARE STEP 2

#51. 5/16" x 5/8"  
Hex Head Bolt (7 pcs)  
#72. 5/16" x 18 x 1.5T  
Flat Washer (6 pcs)  
#99. 5/16" x 19 x 1.5T  
Curved Washer (1 pc)

1. Unravel the Computer Cable (29) and pull the twist tie wire through the Console Mast Cover (38) (see illustration for the correct orientation of the cover) and the Console Mast (2) until the cable connector comes out the top opening of the Console Mast.
2. Attach the Console Mast (2) onto the Main Frame (1) with the seven Hex Head bolts (51). Place six Flat Washers (72) on the side bolts and one Curved Washer (99) on the front bolt. Tighten using the 12/14mm Wrench (100).



# 3 HANDLEBAR

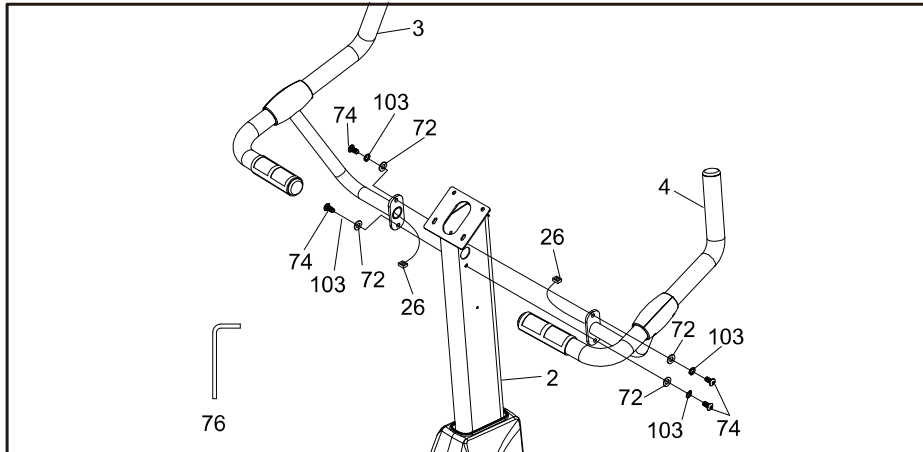

## HARDWARE STEP 3

- #74. 5/16" x 18 x 5/8" Button Head Socket Bolt (4 pcs)
- #72. 5/16" x 18 x 1.5T Flat Washer (4 pcs)
- #103. 5/16" x 1.5T Split Washer (4 pcs)

1. Secure the Seat Handle Bar (**3**) onto the Console Mast (**2**) with the four Button Head Socket Bolts (**74**), four Flat Washers (**72**) and two Split Washers (**103**) by using the Combination M5 Allen Wrench (**76**).
2. Let the two Hand pulse W/Cable Assembly (**26**) through the front of hole on the Console Mast (**2**) and outside.

# 4 PLASTIC PARTS

See next page for illustration

1. Insert the Computer Cable (**29**) and two Hand pulse cables (**26**) into the connectors in the back of the Console (**34**).
2. Attach the Console (**34**) onto the Console Mast (**2**) with four Phillips Head Screws (**58**). Be careful not to pinch the cables when fastening.
3. Install the Pedals (**45 L**, **46 R**) onto the Cranks by using the 13/15mm Wrench (**92**). Remember that the left pedal has a reverse thread and will be screwed into the crank in the opposite rotation from normal threads. There is an L stamped into the end of the threaded post of the left pedal and an R on the end of the right post. Make sure to tighten the pedals as much as you possibly can. It may be necessary to re-tighten the pedals if you feel a thumping while pedalling the bike. A clicking noise or thumping feeling is usually caused by loose pedals.
4. Install the Seat mount slide (**7**) onto the track on top of the seat tube with the seat post facing forward. Place the nut plate (**8**) onto the seat slide behind the seat post. Place the flat washer (**71**) onto the fore/aft adjustment knob (**86**) and thread it into the nut plate from underneath the seat tube track. Attach the seat (**19**) to the seat post using the 12/14mm Wrench (**100**).
5. Secure the Beverage Holder (**116**) onto the Console Mast (**2**) with the two Phillips Head Screws (**58**) by using the Phillips Head Screw Driver (**93**).
6. Install the Tablet Holder (**160**) to back of the console with four Sheet Metal Screws (**161**) by using Phillips Head Screw Driver (**93**).

## HARDWARE STEP 4

- #58. M5 x 12mm Phillips Head Screw (6 pcs)
- #161. 3.5 x 12L Sheet Metal Screw (4 pcs)

# 4 ASSEMBLY STEP 4

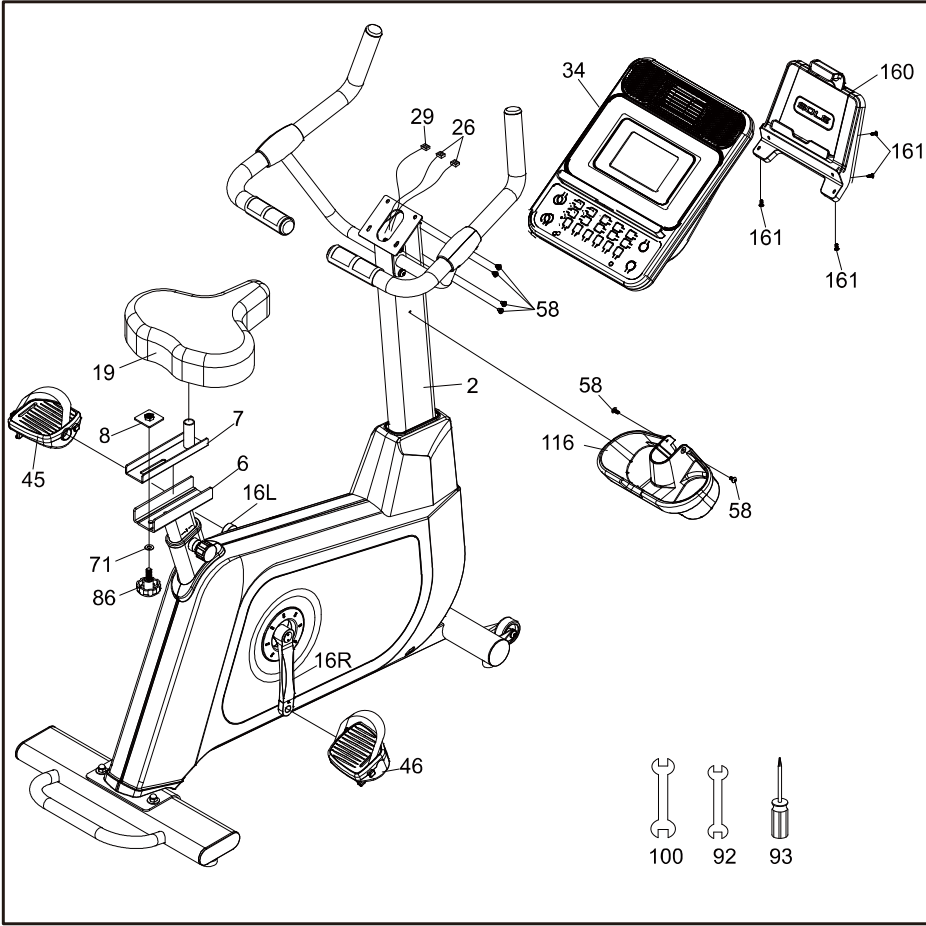

# FITNESS BIKE FEATURES

## FOOT PEDALS

Through research performed with a leading sports scientist and physical rehabilitation expert, Sole engineering has developed a breakthrough in pedal design. Typical stationary exercise bikes are wider than a normal road bike. The reason is to allow for the braking mechanism, pulleys, drive components and plastic covers. Since the bike is wider, so is the distance between the pedals; this width between the pedals is called the Q factor.

Sole has designed our pedal system, so the Q factor is the smallest in the industry, but we did not stop there. We have also custom designed and tooled a new pedal that provides a two degree inward tilt to compensate for the Q factor not being perfect. Having a small Q factor in addition to the two-degree inward tilt of the pedals puts the user into a biomechanical neutral alignment. This means that your feet, ankles, knees and hips are lined up properly, ensuring a comfortable workout.

## SEAT ADJUSTMENT

You are able to adjust the seat position while seated. Pull up on the lever located in front of the seat and slide the carriage forward or backwards. The correct position is when there is a slight bend in your knee when the pedal is at its farthest position forward (3 o'clock position when looking from the right side of the bike). Release the lever, and you are ready to begin.

## PEDAL STRAP ADJUSTMENT

Adjust each pedal strap so that they are snug around your feet. You have the option of adjusting the hole location on one or both sides of the pedal.

# Charge Portable Devices with USB port

USB Port Charging function:

Charge your personal device during your workout using the fitness equipment's on-console USB port.

To charge your mobile electronics make sure the fitness equipment power is on.

Step 1: Connect your USB charging cable (not included) to the USB Power Port and to your device.

Step 2: Check to make sure your device icon indicates it is charging.

NOTE :

\* USB charging cable is not included; make sure compatible USB charging cable is being used.

\*\* Your device "charging" icon may or may not indicate it is charging. Depending on the amount of current your particular device requires for charging, the icon may not be on, but your device is still charging, but possibly at a lower charge rate.

\*\*\*The USB port on the console is capable of powering USB devices. It provides up to 5Vdc/0.5 amp of power and meets USB 2.0 regulations. You will not be able to save your workout data to a USB via this port; it is used for charging purposes only.

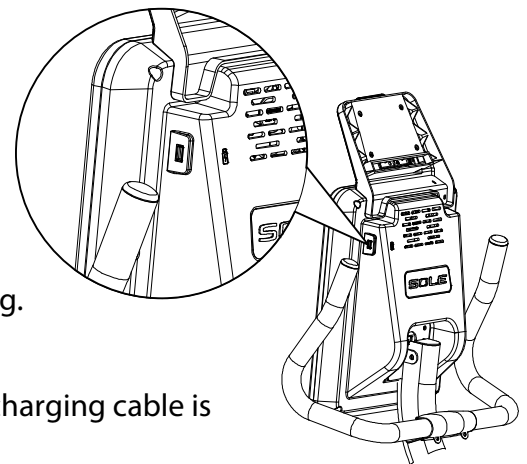

# OPERATION OF YOUR FITNESS BIKE

## GETTING FAMILIAR WITH THE CONTROL PANEL

### CONSOLE



### POWER UP

When power is connected to the fitness bike, the console will automatically power up. These models operate on 12V/3.3A DC, which is supplied by the power pack that is connected to 115 VAC. There is a power socket located where the line cord plugs into the unit on the front of the bike.

When it is first powered on, the console will perform an internal self-test. During this time all the lights will turn on. When the lights go off, the Message Window will show a software version (i.e., VER 1.0), and the Distance window will display an odometer reading. The odometer reading displays how many virtual miles the fitness bike has gone. The Time window displays how many hours the fitness bike has been used.

The odometer and time will remain displayed for only a few seconds then the console will go to the startup display. The dot matrix display will be scrolling through the different workout profiles, and the Message Window will scroll the start-up message. You may now begin to use the console.

# CONSOLE OPERATION

## START KEY

This is the quickest way to start a workout. After the console powers up, just press the Start key to begin. This will initiate the Start key mode. In Start key, the time will count up from zero. The resistance level and incline can be adjusted manually by pressing the Level ▲/▼ buttons. The dot matrix display will be showing a track with a blinking dot indicating your progress as it travels around the track.

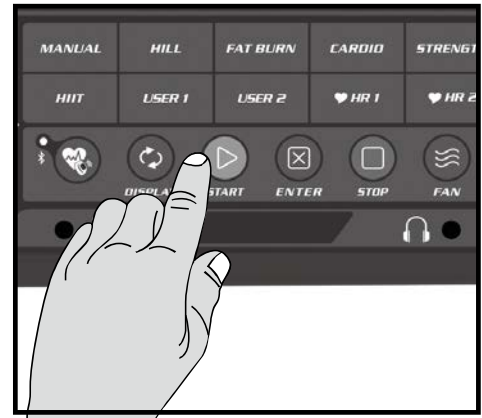

## BASIC INFORMATION

The Message Window will initially display Laps completed. Each time the Display button is pressed, the next set of information will appear. The order of information displayed will be Speed, RPM, Level, Watts, Segment Time and Data Scan mode. In Data Scan mode, the displayed information will change every 4 seconds in the Message Window.

The fitness bike has a built-in heart rate monitoring system. Simply grasping the Contact Heart Rate Sensors on the handle bars or wearing the chest strap transmitter will start the heart (see Heart Rate Programs) Icon blinking (this may take a few seconds). The Pulse Window will display your heart rate in beats per minute, and the HR bar graph will show your current % in relation to projected heart rate maximum. The chest strap is a more accurate and reliable method of heart rate reading. The hand pulse sensors are subject to false readings depending on user physiology and workout habits, including how one grips the sensors or how sweaty their hands are.

The Stop button actually has several functions. Pressing the Stop key once during a program will Pause the program for 5 minutes. If you need to get a drink, answer the phone or any of the many things that could interrupt your workout, this is a great feature. To resume your workout during Pause, just press the Start key. If the Stop button is pressed twice during a workout, the program will end, and a Workout Summary is displayed.



If the Stop/Reset key is held down for 3 seconds, the console will perform a complete Reset. During data entry for a program, the Stop/Reset key performs a Previous Screen function. This allows you to go back one step in the programming each time you press the Stop key.

There is an Audio In Jack (🎵) on the front of the console and built-in speakers. You may plug any low-level audio source signal into this port. Audio sources include MP3, iPod, portable radio, CD player or even a TV or computer audio signal. There is also a Headphone Jack (🎧) for private listening. 

## **PROGRAMMING THE CONSOLE**

Each of the programs can be customized with your personal information and changed to suit your needs. Some of the information asked for is necessary to ensure the readouts are correct. You will be asked for your Age and Weight. Entering your Age is necessary during the Heart Rate control program to ensure the correct settings are entered in the program; entering your Weight aides in calculating a correct Calorie reading. Although we cannot provide an exact calorie count, we do want to be as close as possible.

**A message about Calories:** Calorie readings on every piece of exercise equipment, whether it is in a gym or at home, are not accurate and tend to vary widely. They are meant only as a guide to monitor your progress from workout to workout. The only way to measure your calorie burn accurately is in a clinical setting connected to a host of machines. This is because every person is different and burns calories at a different rate.

## **ENTERING A PROGRAM AND CHANGING SETTINGS**

Press each program button to scroll through the program selections. The profile for each program will be displayed in the dot matrix window. Press the Enter key to select a program and begin customizing the settings. If you want to workout without entering new settings, then just press the Start key. This will bypass the programming of data and take you directly to the start of your workout. If you want to change the personal settings, then just follow the instructions in the Message Window. If you start a program without changing the settings, the default settings will be used.

**Note:** Age and Weight default settings will change when you enter a new number. So the last Age and Weight entered will be saved as the new default settings. If you enter Age and Weight the first time you use the fitness bike, you will not have to enter it every time you work out unless either Age or Weight has changed or someone else enters a different Age and Weight.

# Sole App to be used in conjunction with select Apple & Android devices!

In order to help you achieve your exercise goals, Sole has added an exciting new feature to all of our products. Your new exercise machine comes equipped with a Bluetooth® transceiver that will allow it to interact with selected phones or tablet computers via the Sole Fitness App.

Just download the free Sole Fitness App from the Apple Store or Google Play, and then follow the instructions in the App to sync with your exercise machine. This allows you to view current workout data on three different Display screens on your device. Easily switch back and forth from the workout display view to internet/social media/email sites via icons on the display screen. When your workout is finished, the data is automatically saved to the built-in personal calendar for future reference.

Our new Sole Fitness App also allows you to sync your workout data with one of many fitness cloud sites we support: iHealth, MapMyFitness, Record or Fitbit.

Syncing the App with your exercise machine:

After downloading the App, make sure Bluetooth® is enabled on your device, then click the icon in the top left corner to search for Sole equipment.

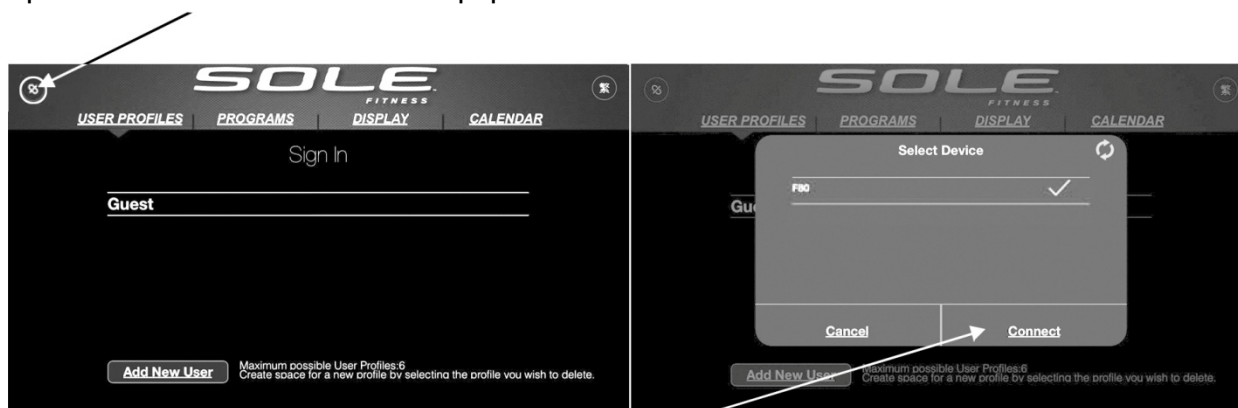

After the equipment is detected, click Connect. When the App and equipment are synced, the Bluetooth® icon on the equipment's console will light up. You may now start using your new Sole product!

If the bike is not connected to the app, the console will display "SYNC" when the workout is over, and you can connect using your phone or tablet to store the bike's workout data in the App. (The console can only store the last workout data when the bike returns to IDLE MODE, the workout data will be erased)

\*Note: Your device will need to be running on a minimum operating system of iOS 7 or Android 4.4 for the Sole Fitness App to operate properly.

## Console + Sole APP + Bluetooth chest strap instructions :

1. When the bike is connected to the APP, press the BLE HR icon.

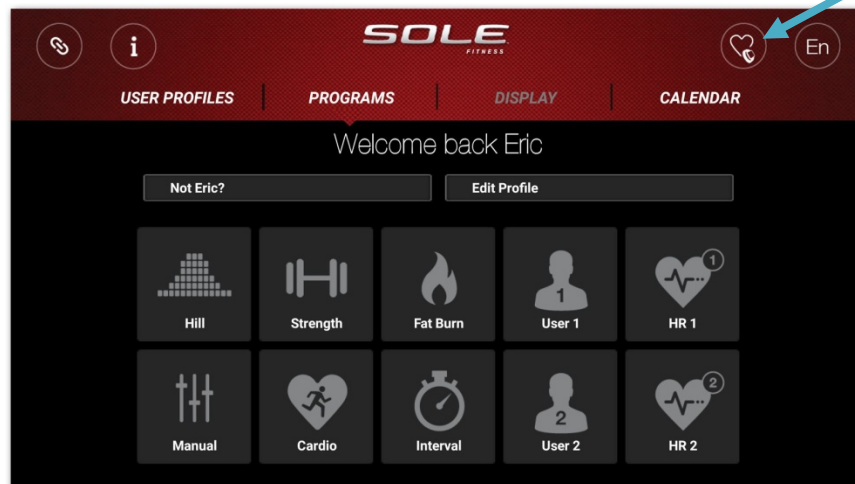

2. Select the heart rate tracking device you use and press Connect.

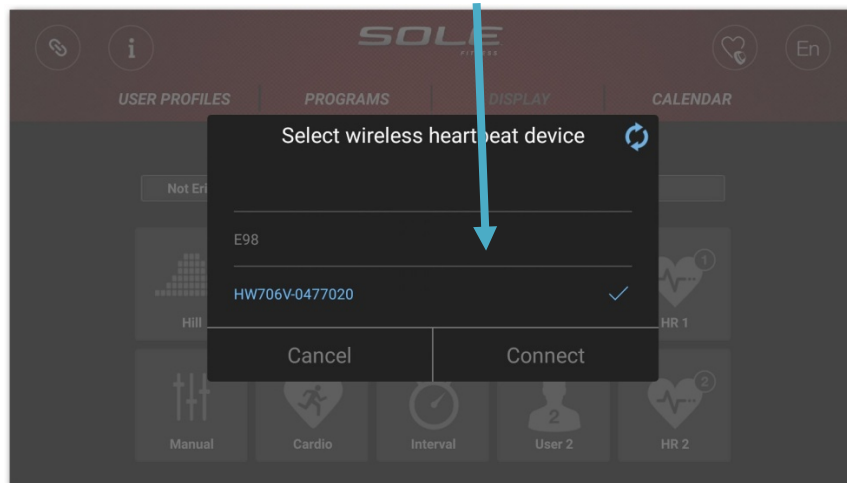

3. During workout, the BLE HR icon will lit up, and your heart rate information will be shown on display.

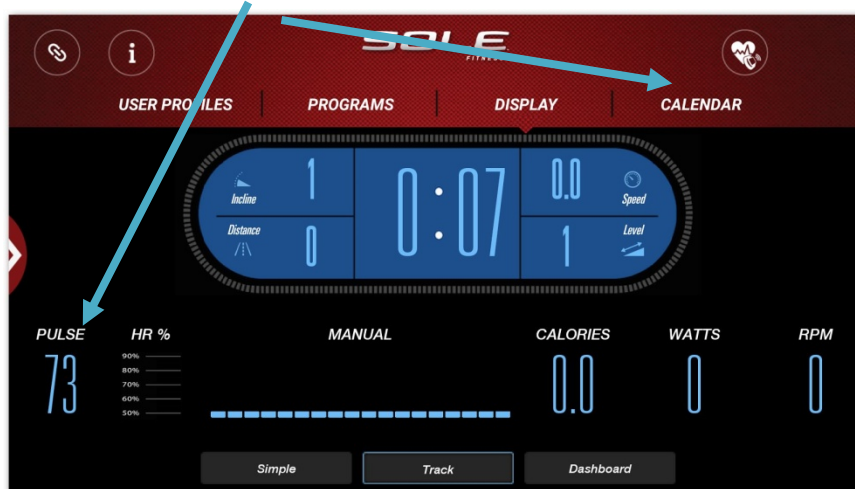

\*Note: Using the APP with the Bluetooth chest strap does not apply to the HRC mode.

The exercise equipment's Bluetooth device (BLE 4.0), in addition to the App, can be connected, but also



configured to connect Bluetooth wireless heart rate chest strap transmitter (BLE 4.0) receive function, because the sharing of Bluetooth device, you need to use the heart rate key on the keyboard to do the function switch, the operating procedures are described as follows:

1. In the idle mode, the heart rate Bluetooth LED on the keypad is not lit, and the Bluetooth function is only used in connection with the App.
2. Under the idle mode, press the heart rate key on the keyboard, the Bluetooth LED light is on, this time the Bluetooth function is only used in connection with Bluetooth wireless heart rate chest strap; please wear the Bluetooth wireless heart rate chest strap, with the console connection, the console shows Bluetooth wireless heart rate value.
3. When the workout is over, the Bluetooth of the console will automatically be switched to the connected App for use.

The exercise equipment is configured with Bluetooth wireless music receive function, using a mobile phone or tablet to open the Bluetooth device, search for the name "Bt-speaker" Bluetooth, click on the connection can transmit the phone or tablet music to the exercise equipment.

# PROGRAMMABLE FEATURES

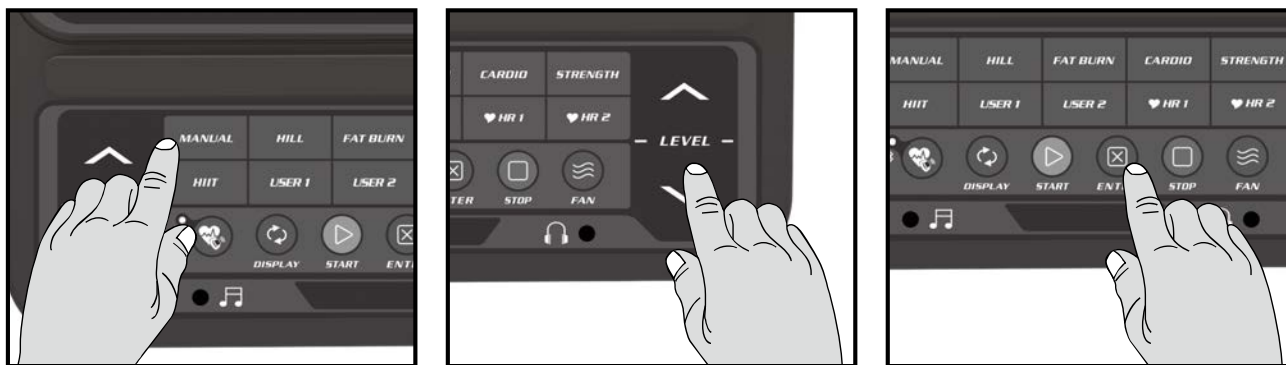

## MANUAL PROGRAM

The Manual program works, as the name implies, manually. This means that you control the workload yourself and not the computer.

1. Press the Manual program button, then press the Enter key.
2. The Message Window will ask you to enter your Age. You may adjust the age setting using the Level ▲/▼ keys, then press the Enter key to accept the new number and proceed on to the next screen.
3. You are now asked to enter your Weight. You may adjust your weight setting using the Level ▲/▼ keys; then press Enter to continue.
4. Next is the Time. You may adjust the length of Time by pressing the Level ▲/▼ keys, then press Enter to continue.
5. Now you are finished editing the settings and can begin your workout by pressing the Start key. You can also go back and modify your settings by pressing the Stop key to go back to one level of the programming screen.
6. Once the program starts, the fitness bike will be set to level one. This is the easiest level, and it is a good idea to stay at level one for a while to warm up. If you want to increase the workload at any time, press the Level ▲ key; the Level ▼ key will decrease the workload.
7. During the Manual program, you will be able to scroll through the data in the Message Window by pressing the Display key.
8. When the program ends, the Message Window will show a summary of your workout. The summary will be displayed for a short time then the console will return to the start-up display.

## PRESET PROGRAMS

The fitness bike has five different programs that have been designed for a variety of workouts. These five programs have factory preset work level profiles for achieving different goals.

### Hill

The Hill program simulates going up and down a hill. The resistance in the pedals will steadily increase and then decrease during the program.

WORK

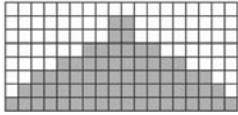

### Fat Burn

The Fat Burn program is designed, as the name implies, to maximize the burning of fat. There are many schools of thought on the best way to burn fat, but most experts agree that a lower exertion level that stays at a steady workload is the best. The absolute best way to burn fat is to keep your heart rate at around 60% to 70% of its maximum potential. This program does not use heart rate but simulates a lower, steady exertion workout.

WORK

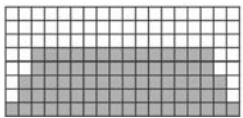

### Cardio

The Cardio program is designed to increase your cardiovascular function and endurance. This is exercise for your heart and lungs. It will build up your heart muscle and increase blood flow and lung capacity. This is achieved by incorporating a higher level of exertion with slight fluctuations in work.

WORK

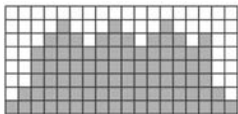

### Strength

The Strength program is designed to increase muscular strength in your lower body. This program will steadily increase in resistance to a high level and forces you to sustain it. This is designed to strengthen and tone your legs and glutes (muscles of the butt).

WORK

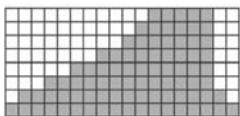

### HIIT

The HIIT program takes you through high levels of intensity followed by periods of low intensity. This program increases your endurance by depleting your oxygen level, followed by periods of recovery to replenish oxygen. Your cardiovascular system gets programmed to use oxygen more efficiently this way. This program also forces your body to become more efficient due to spikes in heart rate between recovery periods. This aids in heart rate recovery from intense activities.

WORK

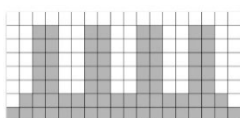

## PROGRAMMING PRESET BUTTONS

1. Press the desired program button, then press the Enter key.
2. The Message Window will ask you to enter your Age. You may adjust the age setting using the Level ▲/▼ keys, then press the Enter key to accept the new number and proceed on to the next screen.
3. You are now asked to enter your Weight. You may adjust the weight number using the Level ▲/▼ keys; then press Enter to continue.
4. Next is Time. You may adjust the Time and press Enter to continue.
5. Now you are asked to adjust the Max Level. This is the peak exertion level you will experience during the program (the highest coloured segment/box of the program profile). Adjust the level and then press Enter.
6. Now you are finished editing the settings and can begin your workout by pressing the Start key. You can also go back and modify your settings by pressing the Stop key to go back one level or screen.
7. During the program, you will be able to scroll through the data in the Message Window by pressing the Display key.
8. When the program ends, the Message Window will show a summary of your workout. The summary will be displayed for a short time then the console will return to the start-up display.

## CUSTOM USER DEFINED PROGRAMS

The customizable User programs allow you to build and save your own workout. You can build your own custom program by following the instructions below.

1. Select the User program (User **1** or User **2**), then press Enter. If you have already saved a program to either User **1** or User **2**, it will be displayed, and you are ready to begin. If not, you will have the option of inputting a username. In the Message Window, the letter "A" will be blinking. Use the Level buttons to select the appropriate first letter of your name (pressing the Up button will switch to the letter "B"; pressing the Down button will switch to letter "Z"). Press Enter when the desired letter is displayed. Repeat this process until all of the characters of your name have been programmed (maximum 7 characters). When finished, press Stop.
2. If there is a program already stored in User, when you press the key, you will have an option to run the program as it is or delete the program and build a new one. At the welcome message screen, when pressing Start or Enter, you will be prompted: Run Program? Use the Level ▲/▼ to select Yes or No. If you select No, you will then be asked if you want to delete the currently saved program. It is necessary to delete the current program if you want to build a new one.
3. The Message Window will ask you to enter your Age. You may enter your age using the Level ▲/▼ keys, then press the Enter key to accept the new number and proceed on to the next screen.
4. You are now asked to enter your Weight. You may adjust the weight number using the Level ▲/▼ keys; then press Enter to continue.
5. Next is Time. You may adjust the Time using the Level ▲/▼ keys and press Enter to continue.
6. Now the first column will be blinking, and you are asked to adjust the level for the first segment of the workout. When you finish adjusting the first segment, or if you don't want to change, then press Enter to continue to the next segment. The next segment will show the same level as the previously adjusted segment. Repeat the same process as the last segment, then press Enter. Continue this process until all eighteen segments have been set.
7. The Message Window will then tell you to start to begin (and save the program) or Enter to modify the program. Pressing Stop will exit to the start up screen.
8. If you want to increase or decrease the workload at any time during the program, press the Level ▲/▼ key. This will only affect the Level for the present column in the profile. When the profile changes to the next column, it will return to the preset work level.
9. During the User **1** or User **2** program, you will be able to scroll through the data in the Message Window by pressing the Display key.
10. When the program ends, the Message Window will show a summary of your workout. The summary will be displayed for a short time then the console will return to the start-up display.

# HEART RATE PROGRAMS

Before we get started, a word about Heart Rate:

The old motto, "no pain, no gain," is a myth that has been overpowered by the benefits of exercising comfortably. A great deal of this success has been promoted by the use of heart rate monitors. With the proper use of a heart rate monitor, many people find that their usual choice of exercise intensity was either too high or too low, and exercise is much more enjoyable by maintaining their heart rate in the desired benefit range.

To determine the benefits range in which you wish to train, you must first determine your Maximum Heart Rate. This can be accomplished by using the following formula: 220 minus your age. This will give you the Maximum Heart Rate (MHR) for someone of your age. To determine the effective heart rate range for specific goals, you simply calculate a percentage of your MHR. Your Heart rate training zone is 50% to 90% of your maximum heart rate. 60% of your MHR is the zone that burns fat, while 80% is for strengthening the cardiovascular system. This 60% to 80% is the zone to stay in for maximum benefit.

For someone who is 40 years old their target heart rate zone is calculated:

$$\begin{aligned} 220 - 40 &= 180 \text{ (maximum heart rate)} \\ 180 \times .6 &= 108 \text{ beats per minute} \\ &\text{(60\% of maximum)} \\ 180 \times .8 &= 144 \text{ beats per minute} \\ &\text{(80\% of maximum)} \end{aligned}$$

So for a 40-year-old, the training zone would be 108 to 144 beats per minute.

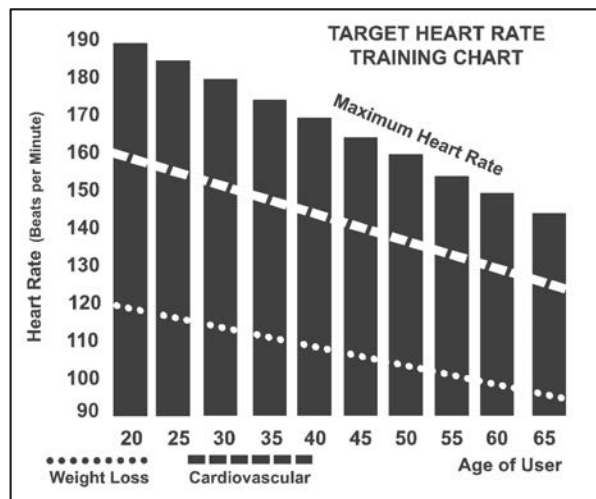

If you enter your age during programming, the console will perform this calculation automatically. Entering your age is used for the Heart Rate control programs. After calculating your MHR, you can decide upon which goal you would like to pursue.

The two most popular reasons for, or goals, of exercise, are cardiovascular fitness (training for the heart and lungs) and weight control. The black columns on the chart above represent the MHR for a person whose age is listed at the bottom of each column. The training heart rate, for either cardiovascular fitness or weight loss, is represented by two different lines that cut diagonally through the chart. A definition of the lines' goal is in the bottom left-hand corner of the chart. If your goal is cardiovascular fitness or if it is weight loss, it can be achieved by training at 80% or 60%, respectively, of your MHR on a schedule approved by your physician. Consult your physician before participating in any exercise program.

With all SOLE Heart Rate Control fitness bike machines, you may use the heart rate monitor feature without using the Heart Rate Control program. This function can be used during manual mode or during any of the nine different programs. The Heart Rate Control program automatically controls resistance at the pedals.

# RATE OF PERCEIVED EXERTION

Heart rate is important but listening to your body also has a lot of advantages. There are more variables involved in how hard you should workout than just heart rate. Your stress level, physical health, emotional health, temperature, humidity, the time of day, the last time you ate and what you ate all contribute to the intensity at which you should workout. If you listen to your body, it will tell you all of these things.

The rate of perceived exertion (RPE), also known as the Borg scale, was developed by Swedish physiologist G.A.V. Borg. This scale rates exercise intensity from 6 to 20 depending upon how you feel or the perception of your effort.

The scale is as follows: Rating  
Perception of Effort

- 6** Minimal
- 7** Very, very light
- 8** Very, very light +
- 9** Very light
- 10** Very light +
- 11** Fairly light
- 12** Comfortable
- 13** Somewhat hard
- 14** Somewhat hard +
- 15** Hard
- 16** Hard +
- 17** Very hard
- 18** Very hard +
- 19** Very, very hard
- 20** Maximal

You can get an approximate heart rate level for each rating by simply adding a zero to each rating. For example, a rating of 12 will result in an approximate heart rate of 120 beats per minute. Your RPE will vary depending on the factors discussed earlier. That is the major benefit of this type of training. If your body is strong and rested, you will feel strong, and your pace will feel easier. When your body is in this condition, you are able to train harder, and the RPE will support this. If you are feeling tired and sluggish, it is because your body needs a break. In this condition, your pace will feel harder. Again, this will show up in your RPE, and you will train at the proper level for that day.

# USING HEART RATE TRANSMITTER

How to wear your wireless chest strap transmitter:

1. Attach the transmitter to the elastic strap using the locking parts
2. Adjust the strap as tightly as possible as long as the strap is not too tight to remain comfortable.
3. Position the transmitter with the logo centred in the middle of your body facing away from your chest (some people must position the transmitter slightly left of center). Attach the final end of the elastic strap by inserting the round end and using the locking parts, secure the transmitter and strap around your chest.
4. Position the transmitter immediately below the pectoral muscles.
5. Sweat is the best conductor to measure very minute heartbeat electrical signals. However, plain water can also be used to pre-wet the electrodes (2 ribbed oval areas on the reverse side of the belt and both sides of the transmitter). It's also recommended that you wear the transmitter strap a few minutes before your workout. Some users, because of body chemistry, have a more difficult time in achieving a strong, steady signal at the beginning. After "warming up," this problem lessens. As noted, wearing clothing over the transmitter/strap doesn't affect performance.
6. Your workout must be within range - the distance between transmitter/receiver - to achieve a strong, steady signal. The length of the range may vary somewhat but generally stay close enough to the console to maintain good, strong, reliable readings. Wearing the transmitter immediately against bare skin assures you of proper operation. If you wish, you may wear the transmitter over a shirt. To do so, moisten the areas of the shirt that the electrodes will rest upon.



Note: The transmitter is automatically activated when it detects activity from the user's heart. Additionally, it automatically deactivates when it does not receive any activity. Although the transmitter is water resistant, moisture can have the effect of creating false signals, so you should take precautions to completely dry the transmitter after use to prolong battery life (estimated transmitter battery life is 2500 hours). The replacement battery is Panasonic CR2032.

## ERRATIC OPERATION

**Caution!** Do not use this fitness bike for Heart Rate Control unless a steady, solid Actual Heart Rate value is being displayed. High, wild, random numbers being displayed indicate a problem.

Areas to look for interference that may cause erratic heart rate:

1. Microwave ovens, TVs, small appliances, etc.
2. Fluorescent lights.
3. Some household security systems.
4. Perimeter fence for a pet.
5. Some people have problems with the transmitter picking up a signal from their skin. If you have problems, try wearing the transmitter upside down. Normally the transmitter will be oriented, so the logo is right side up.
6. The antenna that picks up your heart rate is very sensitive. If there is an outside noise source, turning the whole machine 90 degrees may de-tune the interference.
7. Another Individual wearing a transmitter within 3' of your machine's console.

**If you continue to experience problems, contact your dealer.**

## HEART RATE CONTROL PROGRAM OPERATION

Both programs operate the same; the only difference is that HR1 is set to 60%, and HR2 is set to 80% of the maximum heart rate. They both are programmed the same way.

To start an HRC program, follow the instructions below or just select the HR1 or HR2 program, then the Enter button and follow the directions in the Message Window.

1. Press the HR1 or HR2 key, then press the Enter key.
2. The Message Window will ask you to enter your Age. You may enter your Age, using the Level▲/▼ keys, then press the Enter key to accept the new number and proceed on to the next screen.
3. You are now asked to enter your Weight. You may adjust the Weight number using the Level▲/▼ keys, then press Enter to continue.
4. Next is Time. You may adjust the Time and press Enter to continue.
5. Now you are asked to adjust your Target Heart Rate. This is the heart rate level you will strive to reach and maintain during the program. Adjust the level and then press Enter. NOTE: The heart rate that appears is based on the % you accepted in Step 2. If you change this number, it will either increase or decrease the % from Step 2.
6. Now you are finished editing the settings and can begin your workout by pressing the Start key. You can also go back and modify your settings by pressing the Enter key. NOTE: At any time during the editing of Data, you can press the Stop key to go back one level or screen.
7. If you want to increase or decrease the workload at any time during the program, press the Level▲/▼ key. This will allow you to change your target heart rate at any time
8. during the program.
9. During the HR1 or HR2 programs, you will be able to scroll through the data in the
10. Message Window by pressing the adjacent Display key.
11. When the program ends, you may press Start to begin the same program again or Stop to exit the program.



# GENERAL MAINTENANCE

1. Wipe down all areas in the sweat path with a damp cloth after each workout.
2. If a squeak, thump, clicking, or rough feeling develops, the main cause is most likely one of two reasons:
  - i. The hardware was not sufficiently tightened during assembly. All bolts that were installed during assembly need to be tightened as much as possible. It may be necessary to use a larger wrench than the one provided if you cannot tighten the bolts sufficiently. Ninety percent of calls to the service department for noise issues can be traced to loose hardware.
  - ii. The crank arm nut needs to be retightened
3. If squeaks or other noises persist, check that the unit is properly levelled. There are 2 levelling pads on the bottom of the rear stabilizer; use a 14mm wrench (or adjustable wrench) to adjust the levellers.

## MAINTENANCE MENU IN CONSOLE SOFTWARE

The console has built-in maintenance/diagnostic software. The software will allow you to change the console settings from English to Metric and turn off the beeping of the speaker when a key is pressed, for example. To enter the Maintenance Menu (may be called Engineering mode, depending on version), press and hold down the Start, Stop and Enter keys. Keep holding the keys down for about 5 seconds, and the Message Window will display "Engineering mode." Press the Enter button to access the menu below. Press the Level ▲/▼ keys to navigate the menu.

- A. Key Test
- B. Display Test
- C. Functions
  - i. ODO Reset - Resets the odometer reading to zero
  - ii. Units - Choose from English(Imperial) or Metric display readings
  - iii. Display Mode - Turn off to have the console power down automatically after 30 minutes of inactivity
  - iv. Motor Test - Continually runs the tensioning gear motor
  - v. Manual - Allows stepping of the gear motor
  - vi. Pause Mode - Turn on to allow 5 minutes of pause, turn off to have console pause indefinitely
  - vii. Key Tone - Turn on or off the beep sound when a key is pressed
- D. Security
- E. Factory Settings - For Factory use only
- F. Exit

# B94 EXPLODED VIEW DIAGRAM

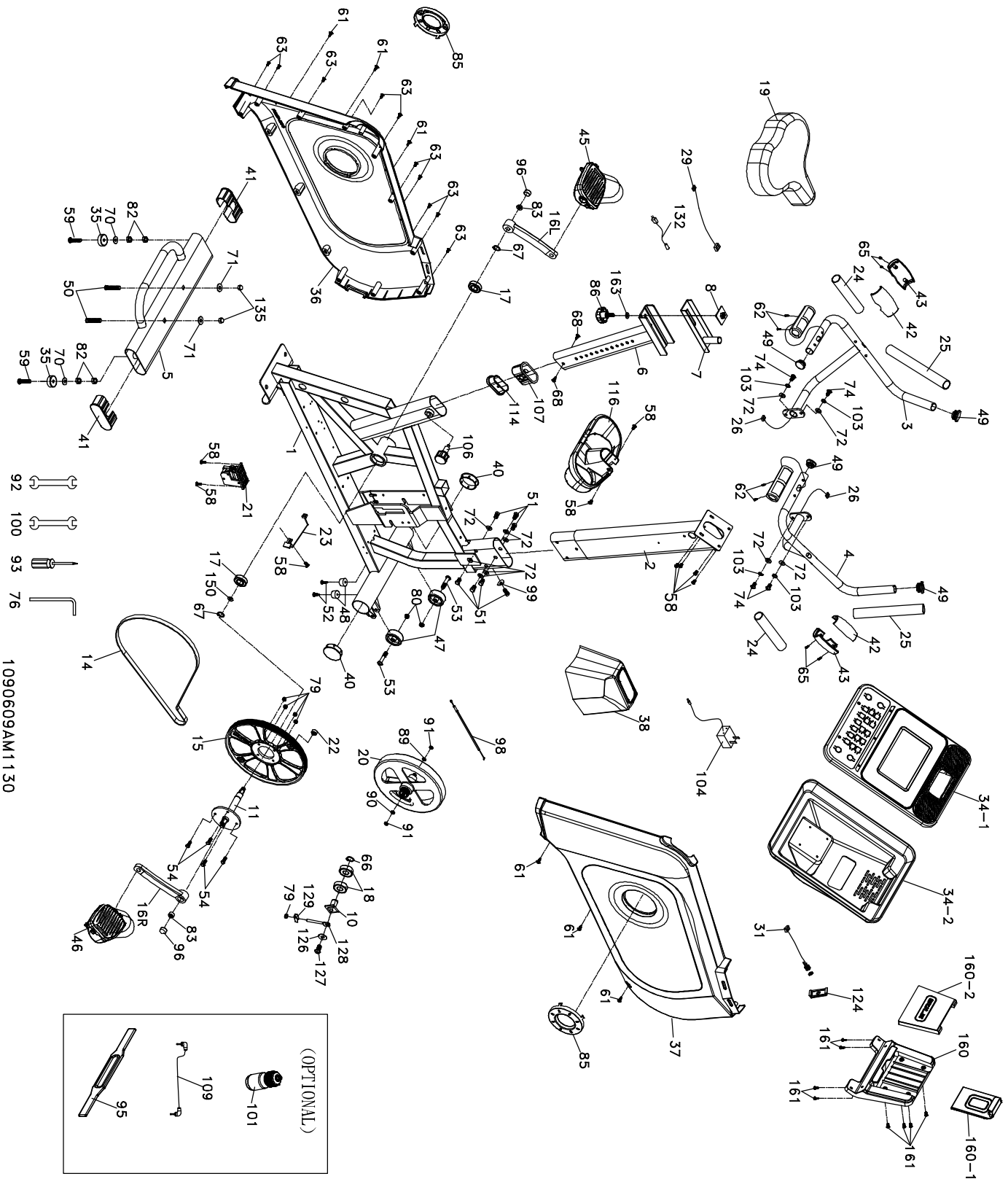

# B94 PARTS LIST

Key	Part	Part Description	Q'ty
1	9609401	Main Frame	1
2	9609402	Console Mast	1
3	9609403	Seat Handle Bar (L)	1
4	9609404	Seat Handle Bar (R)	1
5	9609405	Rear Stabilizer	1
6	9609406	Seat Slider	1
7	9609407	Sliding Seat Mount	1
8	9609408	Fix Plate	1
10	9609410	Bearing Housing	1
11	9609411	Crank Arbor	1
14	9609414	Drive Belt	1
15	9609415	Drive Pulley	1
16L	9609416L	Crank Arm(L)	1
16R	9609416R	Crank Arm(R)	1
17	9609417	6004_Bearing	2
18	9609418	6203_Bearing	2
19	9609419	Seat	1
20	9609420	Flywheel	1
21	9609421	Gear Motor	1
22	9609422	Magnet	1
23	9609423	500m/m_Reed Switch	1
24	9609424	1" × 5T × 180m/m_Handgrip Foam	2
25	9609425	1" × 5T × 300m/m_Handgrip Foam	2
26	9609526	800m/m_Handpulse W/Cable Assembly	2
29	9609429	1000m/m_Computer Cable	1
31	9609431	750m/m_DC Power Cord	1
34	9609434	Console Assembly	1
35	9609435	Ø35 × 10m/m_Rubber Foot	2
36	9609436	Chain Cover (L)	1
37	9609437	Chain Cover (R)	1
38	9609438	Console Mast Cover	1
40	9609440	Ø60.6_Stabilizer End Cap	2
41	9609441	118 × 40m/m_End Cap	2
42	9609442	Handgrip Side Cap (Top)	2
43	9609443	Handgrip Side Cap (Bottom)	2
45	9609445	Pedal (L)	1
46	9609446	Pedal (R)	1
47	9609447	Transportation Wheel	2
48	9609448	Rubber Foot Pad	2
49	9609449	Button Head Plug	4
50	9609450	3/8" × 53L_Carriage Bolt	2
51	9609451	5/16" × 5/8" _Hex Head Bolt	7

Key	Part	Part Description	Q'ty
52	9609452	5 × 19m/m_Tapping Screw	2
53	9609453	5/16" × 1-3/4" _Button Head Socket Bolt	2
54	9609454	1/4" × 3/4" _Hex Head Bolt	4
58	9609458	M5 × 12m/m_Phillips Head Screw	9
59	9609459	3/8" × 2m/m_Flat Head Socket Bolt	2
61	9609461	Ø5 × 16m/m_Tapping Screw	6
62	9609462	Ø3 × 20m/m_Tapping Screw	4
63	9609463	Ø3.5 × 16m/m_Sheet Metal Screw	10
65	9609465	3 × 10m/m_Tapping Screw	4
66	9609466	Ø17_C Ring	1
67	9609467	Ø20_C Ring	2
68	9609468	4 × 12m/m_Sheet Metal Screw	2
70	9609470	Ø3/8" × 19m/m × 1.5T_Flat Washer	2
71	9609471	Ø3/8" × 25m/m × 2T_Flat Washer	2
72	9609472	Ø5/16" × Ø18 × 1.5T_Flat Washer	10
74	9609474	5/16" × UNC18 × 5/8" _Button Head Socket Bolt	4
76	9609476	Combination M5 Allen Wrench & Phillips Head Screw	1
79	9609479	1/4" × 8T_Nyloc Nut	5
80	9609480	5/16" × 9T_Nyloc Nut	2
82	9609482	3/8" × 7T_Nut	4
83	9609483	M10 × 1.25m/m_Nut(Blackfast)	2
85	9609485	Round Cover	2
86	9609486	Brake Tension Knob	1
89	9609489	3/8"-UNF26 × 3T_Nut	1
90	9609490	3/8"-UNF26 × 4T_Nut	1
91	9609491	3/8"-UNF26_Nut	2
92	9609492	13/15m/m_Wrench	1
93	9609493	Phillips Head Screw Driver	1
95	9609495	Chest Strap(Optional)	1
96	9609496	Crank Arm End Cap	2
98	9609498	Steel Cable	1
99	9609499	Ø5/16" × 19 × 1.5T_Curved Washer	1
100	96094100	12/14m/m_Wrench	1
101	96094101	Drink Bottle(Optional)	1
103	96094103	5/16" × 1.5T_Split Washer	4
104	96094104	Power Adaptor	1
106	96094106	Locking Knob	1
107	96094107	Center spatial wrap	1
109	96094109	400m/m_Audio Cable(Optional)	1
114	96094114	Slide Spacer	1
116	96094116	Beverage Holder	1
124	96094124	On/Off Switch Bracket	1
126	96094126	3/8" × 25mm × 3T_Flat Washer	1
127	96094127	M10 × P1.25 × 15L_Button Head Socket Bolt	1
128	96094128	1/4" × 70L_Idle Wheel Screw	1

Key	Part	Part Description	Q'ty
<b>129</b>	<b>96094129</b>	Nut Stopper	1
<b>132</b>	<b>96094132</b>	Transformer Power Cord	1
<b>135</b>	<b>96094135</b>	3/8" × UNC16 × 12.5T_Cap Nut	2
<b>150</b>	<b>96094150</b>	Rubber Pad	1
<b>160</b>	<b>96094160</b>	Tablet Holder (Bottom)	1
<b>160-1</b>	<b>96094160-1</b>	Tablet Holder Adjustable Clip	1
<b>160-2</b>	<b>96094160-2</b>	Tablet Holder (Front)	1
<b>161</b>	<b>96094161</b>	3.5 × 12L_Sheet Metal Screw	8
<b>162</b>	<b>96094162</b>	Ø5/16" × Ø18 × 1.5T_Flat Washer	2
<b>163</b>	<b>96094163</b>	Ø3/8" × 25m/m × 2T_Flat Washer	1

# MANUFACTURER'S LIMITED WARRANTY

Dyaco Canada Inc. warrants all its fitness bike parts for a period of time listed below from the date of retail sale, as determined by sale receipt. Dyaco Canada Inc.'s responsibilities include providing new or remanufactured parts at Dyaco Canada Inc.'s option and technical support to our independent dealers and servicing organizations. In the absence of a dealer or service organization, these warranties will be administered by Dyaco Canada Inc. directly to a consumer. The warranty period applies to the following components:

**B94 - RESIDENTIAL WARRANTY** (All service is performed In-Home)

Parts/Electronics	3 Years
Frame	Lifetime
Labour	1 Year

This warranty applies only to products in ordinary household use, and the consumer is responsible for the items listed below:

1. The warranty registration can be completed online: Go to [www.dyaco.ca/warranty.html](http://www.dyaco.ca/warranty.html) and complete the online warranty registration.
2. Proper use of the fitness bike in accordance with the instructions provided in this manual.
3. Proper installation in accordance with instructions provided with the fitness bike and with all local electric codes.
4. Proper connection to a grounded power supply of sufficient voltage, replacement of blown fuses, repair of loose connections or defects in house wiring.
5. Expenses for making the fitness bike accessible for servicing, including any item that was not part of the fitness bike at the time it was shipped from the factory.
6. Damages to the fitness bike finish during shipping, installation or following installation.
7. Routine maintenance of this unit as specified in this manual.

## EXCLUSIONS

This warranty does not cover the following:

1. CONSEQUENTIAL, COLLATERAL, OR INCIDENTAL DAMAGES SUCH AS PROPERTY DAMAGE AND INCIDENTAL EXPENSES RESULTING FROM ANY BREACH OF THIS WRITTEN OR ANY IMPLIED WARRANTY.  
Note: Some areas do not allow the exclusion or limitation of incidental or consequential damages, so this limitation or exclusion may not apply to you.
2. Service call reimbursement to the consumer. Service call reimbursement to the dealer that does not involve malfunction or defects in workmanship or material, for units that are beyond the warranty period, for units that are beyond the service call reimbursement period, for fitness bike not requiring component replacement, or fitness bike not in ordinary household use.
3. Damages caused by services performed by persons other than authorized Dyaco Canada Inc. service companies; use of parts other than original Dyaco Canada Inc. parts; or external causes such as corrosion, discoloration of paint or plastic, alterations, modifications, abuse, misuse, accident, improper maintenance, inadequate power supply, or acts of God.
4. Products with original serial numbers that have been removed or altered.
5. Products that have been: sold, transferred, bartered, or given to a third party.
6. Products that do not have a warranty registration card on file at Dyaco Canada Inc. Dyaco Canada Inc. reserves the right to request proof of purchase if no warranty record exists for the product.
7. THIS WARRANTY IS EXPRESSLY IN LIEU OF ALL OTHER WARRANTIES EXPRESSED OR IMPLIED, INCLUDING THE WARRANTIES OF MERCHANTABILITY AND/OR FITNESS FOR A PARTICULAR PURPOSE.
8. Product used in any environment other than a residential setting.
9. Warranties outside of North America may vary. Please contact your local dealer for details.

## SERVICE

Keep your bill of sale. The labour warranty period is twelve (12) months from the date on the bill of sale. If service is performed, it is in your best interest to obtain and keep all receipts. This written warranty gives you specific legal rights. You may also have other rights that vary in different areas. Service under this warranty must be obtained by following these steps, in order:

1. Contact your selling authorized SOLE dealer.
2. If you have any questions about your new product or questions about the warranty, contact Dyaco Canada Inc. at 1-888-707-1880.
3. If no local service is available, Dyaco Canada Inc. will repair or replace the parts, at Dyaco Canada Inc.'s option, within the warranty period at no charge for parts. All transportation costs, both to our factory and upon return to the owner, are the responsibility of the owner. The owner is responsible for adequate packaging upon return to Dyaco Canada Inc. Dyaco Canada Inc. is not responsible for damages that occur during shipping. Make all freight damage claims with the appropriate freight carrier. DO NOT SHIP ANY UNIT TO OUR FACTORY WITHOUT A RETURN AUTHORIZATION NUMBER. All units arriving without a return authorization number will be refused.
4. For any further information, or to contact our service department by mail, send your correspondence to:

Dyaco Canada Inc.  
5955 Don Murie Street  
Niagara Falls, ON  
L2G 0A9

Product features or specifications as described or illustrated are subject to change without notice. All warranties are made by Dyaco Canada Inc.

Customer Service 1-888-707-1880  
Email: [customerservice@dyaco.ca](mailto:customerservice@dyaco.ca)

# dyaco

Please visit us online for information about our other brands and products manufactured and distributed by Dyaco Canada Inc.

**SPIRIT**

[spiritfitness.ca](http://spiritfitness.ca)

**XTEERRA**

[xterrafitness.ca](http://xterrafitness.ca)

**UFC**

[dyaco.ca/UFC/UFC-home.html](http://dyaco.ca/UFC/UFC-home.html)

**SOLE**  
FITNESS

[solefitness.ca](http://solefitness.ca)

**EVERLAST**

[dyaco.ca/products/everlast.html](http://dyaco.ca/products/everlast.html)

 *Johnny G*  
by **SPIRIT**

[spiritfitness.ca/johnnyg.html](http://spiritfitness.ca/johnnyg.html)

**TRAINOR**  
**SPORTS**  
[trainorsports.ca](http://trainorsports.ca)

For more information, please contact Dyaco Canada Inc.

T: 1-888-707-1880 | 5955 Don Murie St., Niagara Falls, Ontario L2G 0A9 | [sales@dyaco.ca](mailto:sales@dyaco.ca)

Dyaco Canada Inc. [dyaco.ca](http://dyaco.ca)

**SOLE**<sup>™</sup>  
FITNESS