

SOLE
FITNESS

OWNER'S MANUAL
Model: 16608300950
E95 Elliptical

Please carefully read this entire manual
before operating your elliptical.

ATTENTION: Before returning your SOLE product to any retailer, or if you require any assistance with assembly or technical support please call us first for assistance at 1-888-707-1880. Thank you for your SOLE purchase.

TABLE OF CONTENTS

<u>Product Registration</u>	1
<u>Important Safety Instructions</u>	2
<u>Important Electrical Instructions</u>	3
<u>Important Operation Instructions</u>	4
<u>Transport Instructions</u>	4
<u>E95 Assembly Instructions</u>	8
<u>Elliptical Features</u>	12
<u>Charging Function</u>	12
<u>Operation of Your New Elliptical</u>	13
<u>Bluetooth® Connectivity</u>	15
<u>Using Heart Rate Transmitter</u>	24
<u>General Maintenance</u>	25
<u>Exploded View Diagram</u>	26
<u>Parts List</u>	27
<u>Manufacturer's Limited Warranty</u>	32

ATTENTION

THIS ELLIPTICAL IS INTENDED FOR **RESIDENTIAL USE ONLY** AND IS WARRANTED FOR THE APPLICATION. ANY OTHER APPLICATION **VOIDS** THIS WARRANTY IN ITS ENTIRETY.

SOLE

FITNESS

CONGRATULATIONS ON YOUR NEW ELLIPTICAL AND WELCOME TO THE SOLE FAMILY!

Thank you for purchasing this quality Sole elliptical from Dyaco Canada Inc. Your new elliptical has been manufactured by one of the leading fitness manufacturers in the world and is backed by one of the most comprehensive warranties available. Dyaco Canada Inc. will do all we can to make your ownership experience as pleasant as possible for many years to come.

If you have any questions about your new Sole product or questions about the warranty contact Dyaco Canada Inc. at 1-888-707-1880.

Please take a moment at this time to record below the name of the dealer, their telephone number, and the date of purchase for easy contact in the future. We appreciate your confidence in SOLE and we will always remember that you are the reason that we are in business. Please go to www.dyaco.ca/warranty and complete the online warranty registration.

Yours in Health,
Dyaco Canada Inc.

Name of Dealer _____
Telephone Number of Dealer _____
Purchase Date _____

PRODUCT REGISTRATION

RECORD YOUR SERIAL NUMBER

Please record the Serial Number of this fitness product in the space provided below.

Serial Number _____

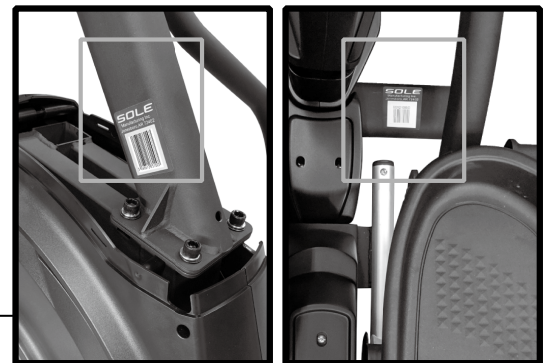

Register your purchase

The self-addressed product registration card must be completed in full and returned to Dyaco Canada Inc.

Please visit us at www.dyaco.ca/warranty to register your purchase.

IMPORTANT SAFETY INSTRUCTIONS

WARNING - Read all instructions before using this equipment.

DANGER - To reduce the risk of electric shock disconnect your SOLE elliptical from the electrical outlet before cleaning and/or service work.

WARNING - To reduce the risk of burns, fire, electric shock, or injury to persons, install the elliptical on a flat level surface with access to a 115-volt, 15-amp grounded outlet with only the elliptical plugged into the circuit.

DO NOT USE AN EXTENSION CORD UNLESS IT IS A 14AWG OR BETTER, WITH ONLY ONE OUTLET ON THE END: DO NOT ATTEMPT TO DISABLE THE GROUNDED PLUG BY USING IMPROPER ADAPTERS, OR IN ANY WAY MODIFY THE CORD SET.

A serious shock or fire hazard may result along with computer malfunctions. See Grounding Instructions, page 3.

- Do not operate elliptical on deeply padded, plush or shag carpet. Damage to both carpet and elliptical may result.
- Keep children under the age of 13 away from this machine. There are obvious pinch points and other caution areas that can cause harm.
- Keep hands away from all moving parts.
- Never operate the elliptical if it has a damaged cord or plug. If the elliptical is not working properly, call your dealer.
- Keep the cord away from heated surfaces.
- Do not operate where aerosol spray products are being used or where oxygen is being administered. Sparks from the motor may ignite a highly gaseous environment.
- Never drop or insert any object into any openings.
- Do not use outdoors.
- To disconnect, turn all controls to the off position and then remove the plug from the outlet.
- Do not attempt to use your elliptical for any purpose other than for the purpose it is intended.
- The hand pulse sensors are not medical devices. Various factors, including the user's movement, may affect the accuracy of heart rate readings. The pulse sensors are intended only as exercise aids in determining heart rate trends in general.
- Wear proper shoes. High heels, dress shoes, sandals or bare feet are not suitable for use on your elliptical. Quality athletic shoes are recommended to avoid leg fatigue.
- This equipment is not intended for use by persons with reduced physical, sensory or mental capabilities, or lack of experience and knowledge unless they have been given supervision or instruction concerning the use of the equipment by a person responsible for their safety.

SAVE THESE INSTRUCTIONS - THINK SAFETY!

IMPORTANT ELECTRICAL INSTRUCTIONS

WARNING!

NEVER remove any cover without first disconnecting AC power.

If voltage varies by ten percent (10%) or more, the performance of your elliptical may be affected. **Such conditions are not covered under your warranty.** If you suspect the voltage is low, contact your local power company or a licensed electrician for proper testing.

NEVER expose this elliptical to rain or moisture. This product is **NOT** designed for use outdoors, near a pool or spa, or in any other high-humidity environment. The operating temperature specification is 40 to 120 degrees Fahrenheit, and humidity is 95% non-condensing (no water drops forming on surfaces).

GROUNDING INSTRUCTIONS

This product must be grounded. If the elliptical should malfunction or break, grounding provides a path of least resistance for electric current, reducing the risk of electric shock. This product is equipped with a cord having an equipment-grounding plug. The plug must be plugged into an appropriate outlet that is properly installed and grounded by all local codes and ordinances.

DANGER - Improper connection of the equipment-grounding conductor can result in a risk of electric shock. Check with a qualified electrician or serviceman if you are in doubt as to whether the product is properly grounded. Do not modify the plug provided with the product if it will not fit the outlet; have a proper outlet installed by a qualified electrician.

This product is for use on a nominal 115-volt circuit and has a grounding plug that looks like the plug illustrated below. A temporary adapter that looks like the adapter illustrated below may be used to connect this plug to a 2-pole receptacle as shown below if a properly grounded outlet is not available. The temporary adapter should be used only until a properly grounded outlet, (shown below) can be installed by a qualified electrician. The green-coloured rigid ear-lug, or the like, extending from the adapter, must be connected to a permanent ground such as a properly grounded outlet box cover. Whenever the adapter is used, it must be held in place by a metal screw.

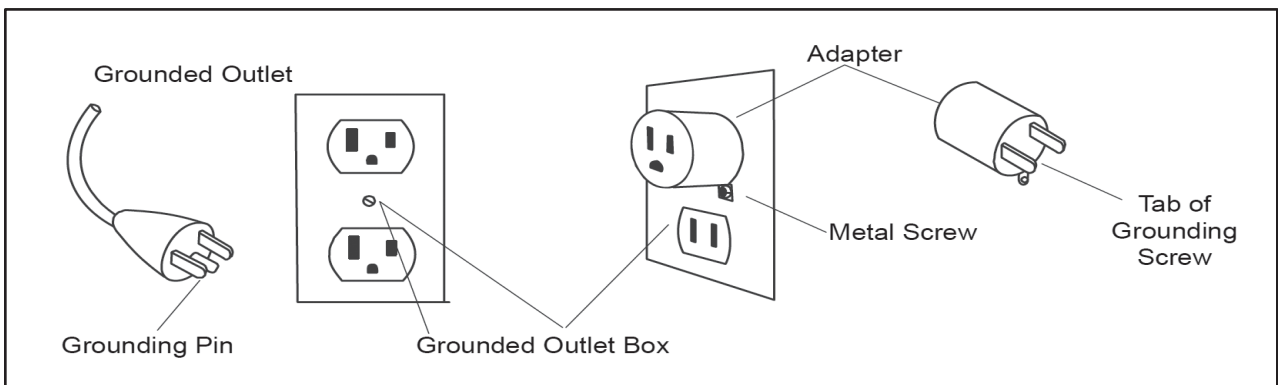

IMPORTANT OPERATION INSTRUCTIONS

- **NEVER** operate this elliptical without reading and completely understanding the results of any operational change you request from the computer.
- Understand that changes in resistance and incline do not occur immediately. Set your desired resistance level on the computer console and release the adjustment key. The computer will obey the command gradually.
- **NEVER** use your elliptical during an electrical storm. Surges may occur in your household power supply that could damage elliptical components. Unplug the elliptical during an electrical storm as a precaution.
- Use caution while participating in other activities while using your elliptical, such as watching television, reading, etc. These distractions may cause you to lose balance, which may result in serious injury.
- Always hold on to a handlebar while making control changes (incline, level, etc.).
- Do not use excessive pressure on console control keys. They are precision set to function properly with little finger pressure. If you feel the buttons are not functioning properly with normal pressure, contact your **SOLE** dealer.



POWER CONNECTOR - FRONT, LEFT SIDE OF UNIT

TRANSPORT INSTRUCTIONS

The elliptical is equipped with two transport wheels which are engaged when the rear of the elliptical is lifted.

E95 ASSEMBLY PACK CHECKLIST

1 HARDWARE STEP 1

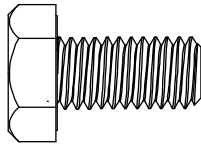

#130. 3/8" × 3/4"_
Hex Head Bolt (2 pcs)

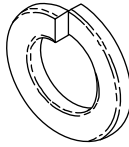

#174. Ø10 × 2T_
Split Washer (10 pcs)

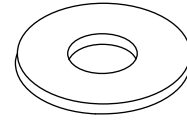

#170. Ø3/8" × Ø19 × 1.5T_
Flat Washer (10 pcs)

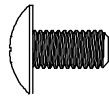

#143. M5 × 10mm_
Phillips Head Screw
(2 pc)

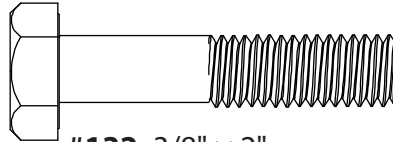

#132. 3/8" × 2"_
Hex Head Bolt
(4 pcs)

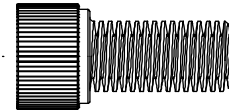

#138. 3/8" × 3/4"_
Socket Head Cap Bolt
(4 pcs)

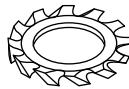

#195. Ø10_
Star Washer (4 pc)

2 HARDWARE STEP 2

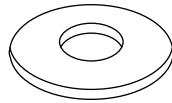

#166. Ø5/16" × Ø20 ×
1.5T_
Flat Washer (6 pc)

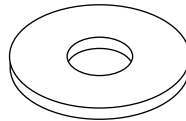

#168. Ø5/16" × Ø23 ×
3T_
Flat Washer (4 pc)

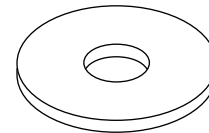

#171. Ø3/8" × 30 × 2.0T_
Flat Washer (2 pc)

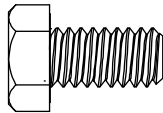

#127. 5/16" × 15mm_
Hex Head Bolt
(8 pc)

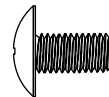

#143. M5 × 10mm_
Phillips Head Screw
(4 pc)

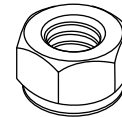

#156. M8 × 7T_
Nylon Nut (2 pc)

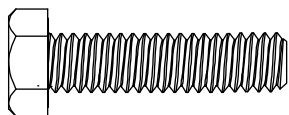

#128. 5/16" × 1-1/4"_
Hex Head Bolt (2 pc)

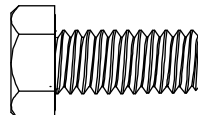

#131. 3/8" × 3/4"_
Hex Head Bolt (2 pc)

3 HARDWARE STEP 3

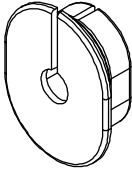
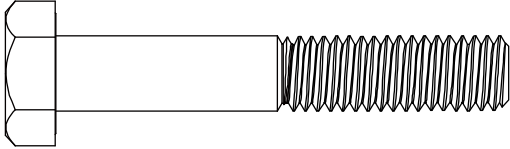
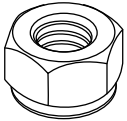
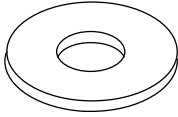
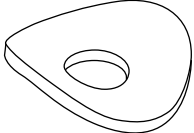
		
<p>#71. Switch Wire Cap (2 pc)</p>	<p>#133. 3/8" × 2-1/4" Hex Head Bolt (6 pc)</p>	
		
<p>#159. 3/8" × 7T Nylon Nut (6 pc)</p>	<p>#170. Ø3/8" × Ø19 × 1.5T Flat Washer (8 pc)</p>	<p>#173. Ø3/8" × 23 × 2.0T Curved Washer (4 pc)</p>

4 HARDWARE STEP 4

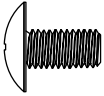
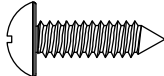
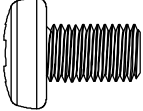
		
<p>#143. M5 × 10mm Phillips Head Screw (22 pcs)</p>	<p>#146. 3.5 × 12mm Sheet Metal Screw (24 pcs)</p>	<p>#148. M6 × 10mm Phillips Head Screw (4 pcs)</p>

ASSEMBLY TOOLS

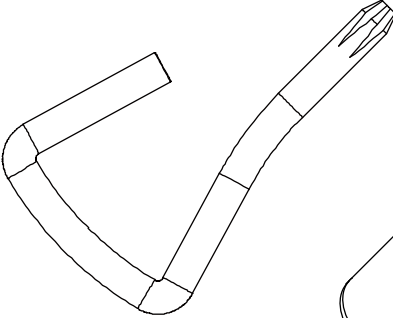
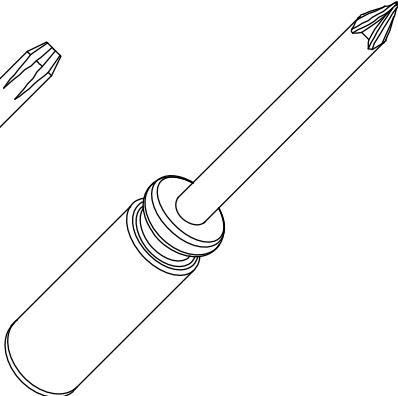
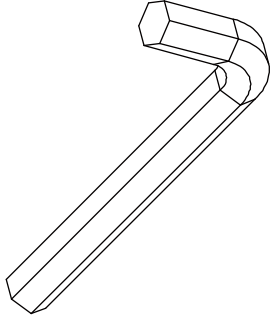
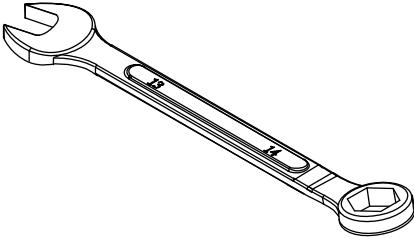
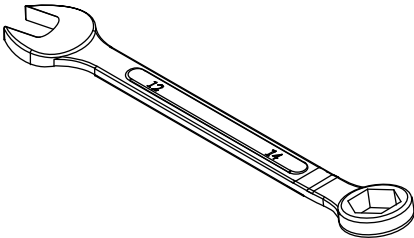
		
<p>#180. Short Phillips Head Screwdriver</p>	<p>#181. Phillips Head Screwdriver</p>	<p>#182. L Allen Wrench</p>
		
<p>#183. 13/14m/m Wrench</p>	<p>#184. 12/14m/m Wrench</p>	

E95 ASSEMBLY INSTRUCTIONS

PRE-ASSEMBLY

1. Using a razor knife (Box Cutter) cut the outside, bottom, and edge of the box along the dotted line. Lift the Box over the unit and unpack.
2. Carefully remove all parts from the carton and inspect for any damage or missing parts. If damaged parts are found, or parts are missing, contact your dealer immediately.
3. Locate the hardware package. Remove the tools first. Remove the hardware for each step as needed to avoid confusion. The numbers in the instructions that are in parenthesis (#) are the item numbers from the assembly drawing for reference.

REMOVE SHIPPING STABILIZER

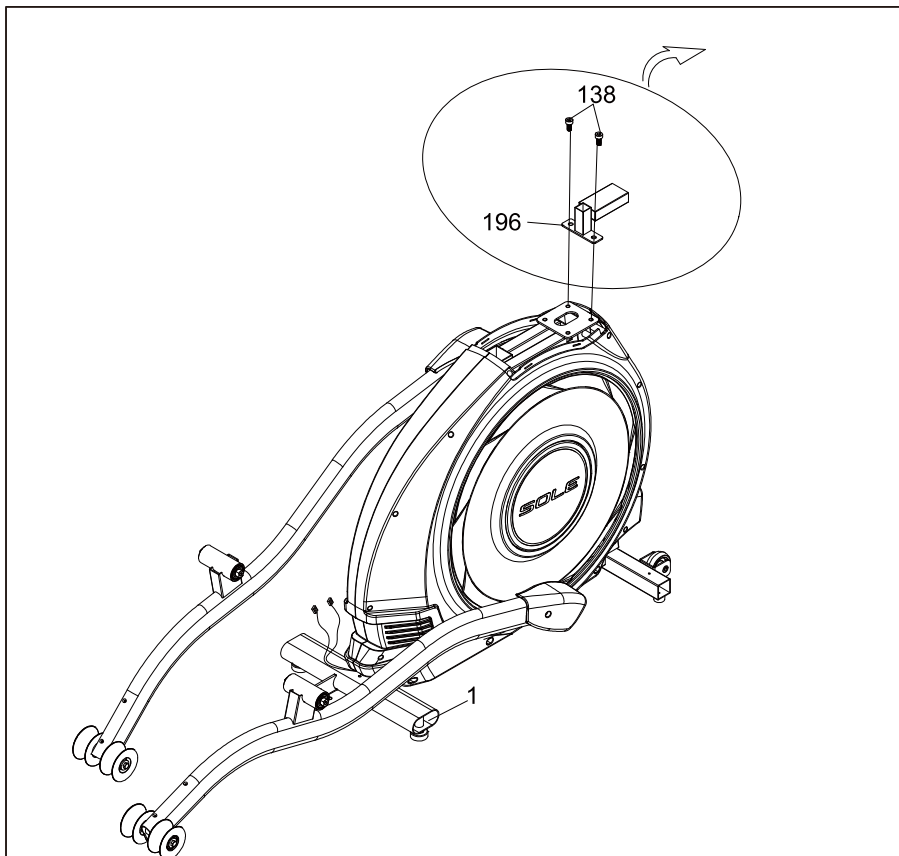

Use M8_L Allen Wrench (**182**) to release two Socket Head Cap Bolts, which are on the mainframe for securing the mast tube, to remove and abandon the Side Back (**196**).

E95 ASSEMBLY INSTRUCTIONS

1 INCLINE RAIL AND CONSOLE MAST

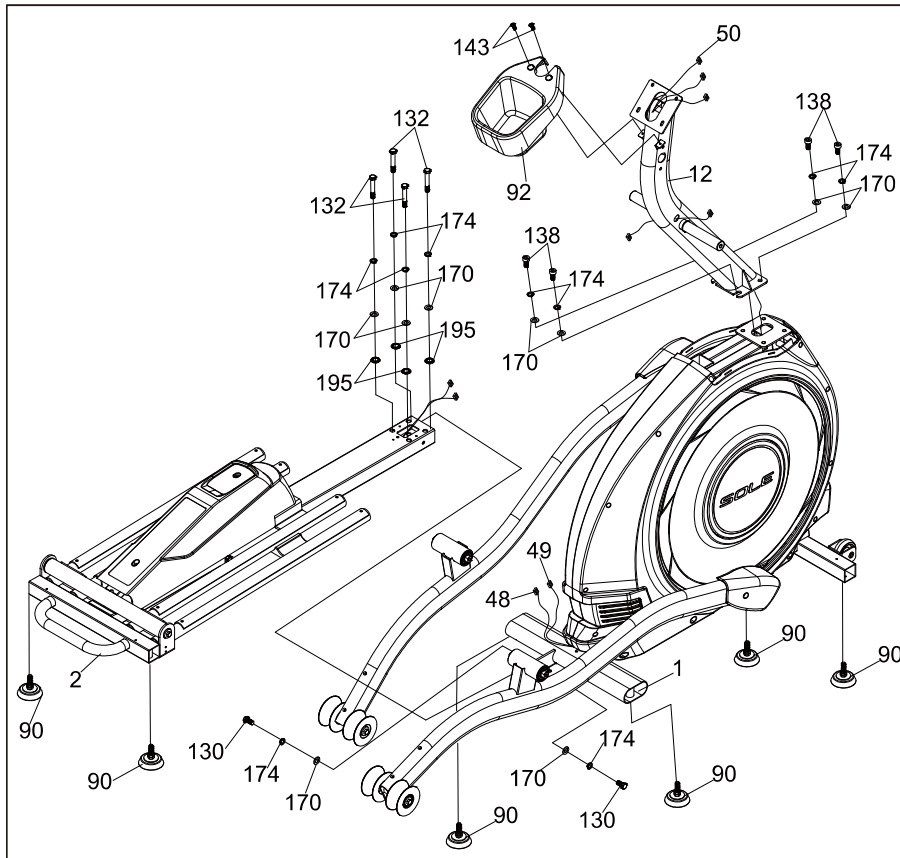

HARDWARE STEP 1

- #130. 3/8" × 3/4" Hex Head Bolt (2 pcs)
- #132. 3/8" × 2" Hex Head Bolt (4 pcs)
- #138. 3/8" × 3/4" Socket Head Cap Bolt (4 pcs)
- #143. M5 × 10mm Phillips Head Screw (2 pc)
- #170. Ø3/8" × Ø19 × 1.5T Flat Washer (10 pcs)
- #174. Ø10 × 2T Split Washer (10 pcs)
- #195. Ø10 Star Washer (4 pc)

1. Install 6pcs Adjustment Foot (**90**) to the Front Stabilizer and Middle Stabilizer of the Main Frame (**1**) and the Rear Stabilizer of the Incline Rail Assembly(**2**).
2. Install the Incline Rail Assembly (**2**) into the U-channel bracket of the Main Frame (**1**). Secure with the four bolts & associated hardware as follows: From the sides install 2pcs Hex Head Bolts (**130**) with 4pcs Hex Head Bolts (**132**), 6pcs Split Washers (**174**), 6pcs Flat Washers (**170**) and 4pcs Star Washers(**195**), as shown in figure 1, and tighten with Wrench (**183**).
3. Connect the 3-wire harness: Incline Motor Power Cord (**48**) to the female receiver cable coming from the Incline Rail Assembly (**2**). Connect the Three pin position Sensor connector: Incline Motor Connecting Wire (**49**) to the female receiver coming from the Incline Rail Assembly (**2**)
4. Run the Computer Cable (**50**) through the Console Mast (**12**), pull the opposite end of this twist tie up through the Console Mast (**12**) until the cable exits the top. Install the Console Mast (**12**) into the receiving bracket on the top of the Main Frame (**1**). Install 4pcs Socket Head Cap Bolts (**138**) with 4pcs Split Washer (**174**), and 4pcs Flat Washers (**170**) and tighten with the provided L Allen Wrench (**182**). Pull slightly on the computer cable at the top of the mast while installing. This will ensure the cable does not get pinched and shorted during console mast assembly.
5. 4. Install the Bottle Holder (**92**) to the Console Mast (**12**) with 2pcs Phillips Head Screws (**143**) and tighten with the provided Phillips Head Screwdriver. (**181**).

E95 ASSEMBLY INSTRUCTIONS

2 LOWER HANDLEBAR ARMS

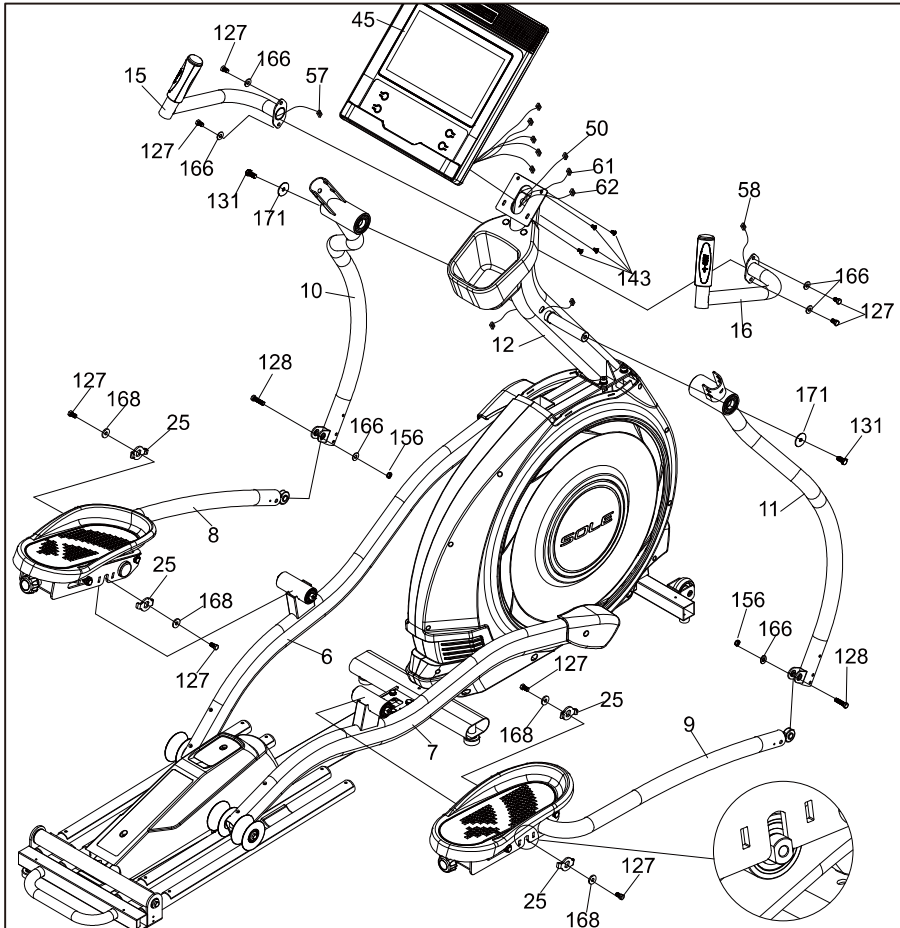

HARDWARE STEP 2

- #127. 5/16" × 15mm_ Hex Head Bolt (8 pc)
- #128. 5/16" × 1-1/4"_ Hex Head Bolt (2 pc)
- #131. 3/8" × 3/4"_ Hex Head Bolt (2 pc)
- #143. M5 × 10mm_ Phillips Head Screw (4 pc)
- #156. M8 × 7T_ Nylon Nut (2 pc)
- #166. Ø5/16" × Ø20 × 1.5T_ Flat Washer (6 pc)
- #168. Ø5/16" × Ø23 × 3T_ Flat Washer (4 pc)
- #171. Ø3/8" × 30 × 2.0T_ Flat Washer (2 pc)

1. Align the plate of Pedal Bar Assembly (L) (8) and the foot pad axle of Left Pedal Arm (6), then put it in it. Secure the Fixing Axle (25) with 2pcs Flat Washer (168) and, 2pcs Hex Head Bolt (127) by using a Wrench (184). Same way to secure the Pedal Bar Assembly (R) (9) on the Right Pedal Arm (7).
2. Install the left and right Lower Handlebar (10) (11) onto the left side and right side of the Console mast shafts, respectively and secure with Hex Head Bolts (131) together with Flat Washers (171) by using Wrench (183).
3. Untie the rod end bearing on the Pedal Bar Assembly (L) (8). Insert Hex Head Bolt (128) through the rod end bearing bracket on Lower Handlebar (L) (10) and use a wrench (183&184) to tighten together with Flat Washer (166) and Nylon Nut (156) in the rod end bearing bracket on the lower Handlebar left (10). Fix the Lower Handlebar (R) (11) and Pedal Bar Assembly (R) (9) in the same way and hardware.
4. Run the Handpulse W/Cable (57) from the Left Handpulse Assembly (15) through the left round hole of the console mast and pull out Handpulse W/Cable (57) to the top from console mast. Secure to the console mast left side with 2pcs Hex Head Bolt (127) and 2pcs Flat Washer (166) by using Wrench (184). The same way to run the Handpulse W/Cable (58) from the Right Handpulse Assembly (16) through the right round hole of the console mast and pull out the Handpulse W/Cable (58) to the top from console mast, and secure to the console mast right side.
5. Plug all of the connectors into the back of the console; Computer Cable (50), two Hand pulse Cables (57&58), Resistance handle wire (61) and Incline handle wire (62). Secure the Console (45) on the console mounting plate with 4pcs Phillips Head Screws (143) by tightening them with Phillips Head Screwdriver (181).

3 TOP HANDLEBARS

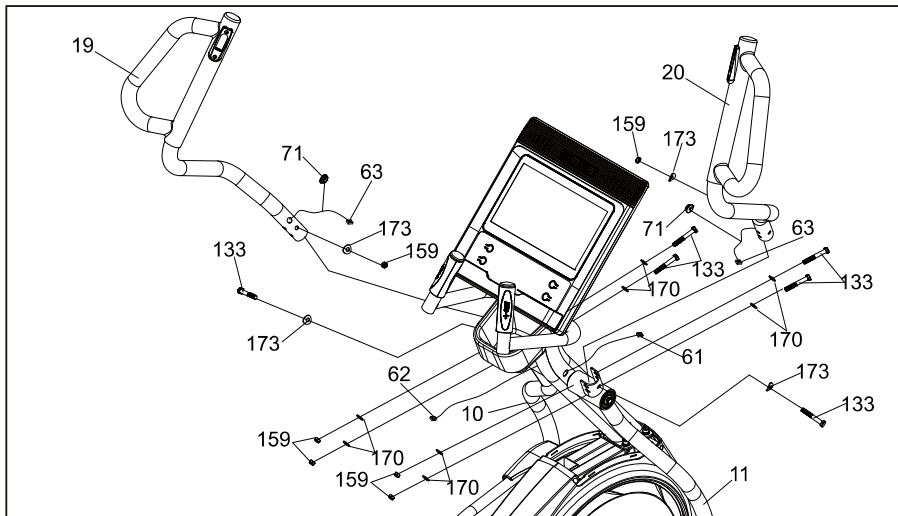

HARDWARE STEP 3

- #71. Switch Wire Cap (2 pc)
- #133. 3/8" × 2-1/4" Hex Head Bolt (6 pc)
- #159. 3/8" × 7T Nylon Nut (6 pc)
- #170. Ø3/8" × Ø19 × 1.5T Flat Washer (8 pc)
- #173. Ø3/8" × 23 × 2.0T Curved Washer (4 pc)

1. Insert the left Top Handlebar (19) onto the left Lower Handlebar and secure with 3pcs Hex Head Bolts (133), and 4pcs Flat Washers (170), 2pcs Curved Washers (173) and 3pcs Nylon Nuts (159) by using 2 Wrench (183&184). The same way to secure the right Top Handlebar (20) on the right Lower Handlebar.
2. Connect the Upper Resistance Handle Wire (61) with the Lower Resistance/Incline Handle Wire (63) store it in the frame tube and snap in the Switch Wire Cap (71) on the console mast. Again, connect the Upper Incline Handle Wire (62) with the Lower Resistance/Incline Handle Wire (63) and store it in the frame tube. Snap-in Switch Wire Cap (71) on the console mast.

E95 ASSEMBLY INSTRUCTIONS

4 PLASTIC PARTS

HARDWARE STEP 4

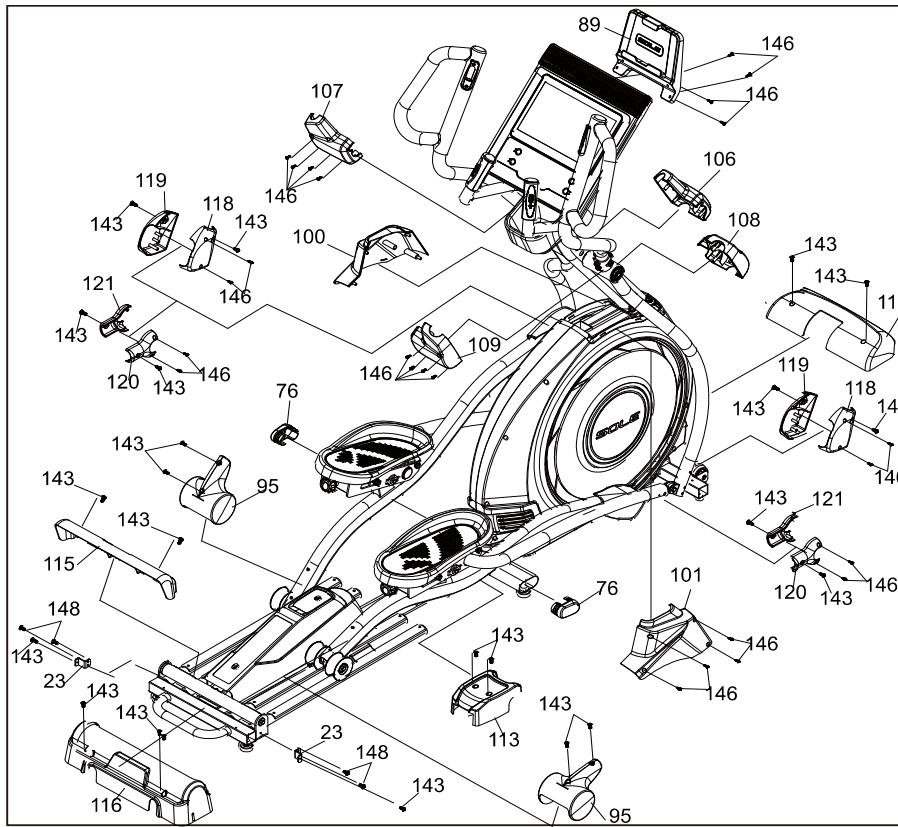

- #143. M5 × 10mm_ Phillips Head Screw (22 pcs)
- #146. 3.5 × 12mm_ Sheet Metal Screw (24 pcs)
- #148. M6 × 10mm_ Phillips Head Screw (4 pcs)

1. Match the Connecting Arm Covers B (L) and (R), (121) and (120), on Pedal Bar Assembly (L) (8) and secure with 2pcs Phillips Head Screws (143) and 2pcs Sheet Metal Screws (146). Then match the Connecting Arm Covers A (R) and (L), (118) and (119), on the lower portion of the Lower Handlebar (L) (10) and secure with 2pcs Phillips Head Screws (143) and 2pcs Sheet Metal Screws (146) by using Short Phillips Head Screwdriver (180). Repeat for the other side.
2. Install Slide Wheel Covers (95) above each side of the Slide Wheel, Urethanes and secure with 4pcs Phillips Head Screws (143) by using Phillips Head Screwdriver (181).
3. Use 2pcs Phillips Head Screws (143) to secure Front Stabilizer Cover (112) on the front stabilizer with Phillips Head Screwdriver (181).
4. Install the Cover Holders (23), with the hole for mounting the plastic cover on the bent tab facing rearward and secure them on the Incline Rail Assembly (2) with 4pcs Phillips Head Screws (148). Install the Inclined Rail Cover (115) on the rail base with 2pcs Phillips Head Screws (143). Secure Rear Bar Cover (116) on the Rear Stabilizer and the Cover Holders (23) with 4pcs Phillips Head Screws (143) by using Phillips Head Screwdriver (181).
5. Secure Bottom Cover (113) on the Incline Rail Assembly (2) with 2pcs Phillips Head Screws (143) by using Phillips Head Screwdriver (181).
6. Install the Handlebar Covers (106 & 107, 108 & 109) over the Handlebar axle connections and secure with 4pcs Sheet Metal Screws (146) by using Phillips Head Screwdriver (181).
7. Match right and left Console Mast Cover (100 & 101). Install the covers with 4pcs Sheet Metal Screws (146) to the Console Mast (12).
8. Install the Tablet Holder (89) to the back of the console with 4pcs Sheet Metal Screws (146).
9. Plug in both Oval End Caps (76) onto both ends of the stabilizer tube.

ELLIPTICAL FEATURES

ADJUSTABLE FOOT PEDAL

To adjust the footpad angles, turn the red knob on the rear of both pedals. The pedal goes **UP** when turning in the **CLOCKWISE** direction; the pedal goes **DOWN** when turning in the **COUNTERCLOCKWISE** direction.

** Make sure to adjust both pedals at the same position.



INCLINE ADJUSTMENT

The E95 has an incline feature that will further increase the variety of your workouts. When the incline is at its lowest position you get a normal elliptical workout. As the incline increases you will feel your knees rise higher with each step, which means you are involving more muscle fibres, due to the increased range of motion.

The E95 has a computer-controlled power incline. The power incline can be controlled by the buttons on the console or the swing arms. It will automatically adjust via the incline motor when you exercise using the built-in workout program.

Wireless Charging

Wireless Charging function:

Charge your device during your workout by placing it inside the wireless charging box/area properly.

NOTE :

** Your device must be set in the landscape orientation for the best result.

** Your device's "charging" icon will indicate it is charging.

*** It provides up to 10 watts of power for many cell phones supporting wireless charging functions.



OPERATION OF YOUR ELLIPTICAL

GETTING FAMILIAR WITH THE CONTROL PANEL

E95 CONSOLE

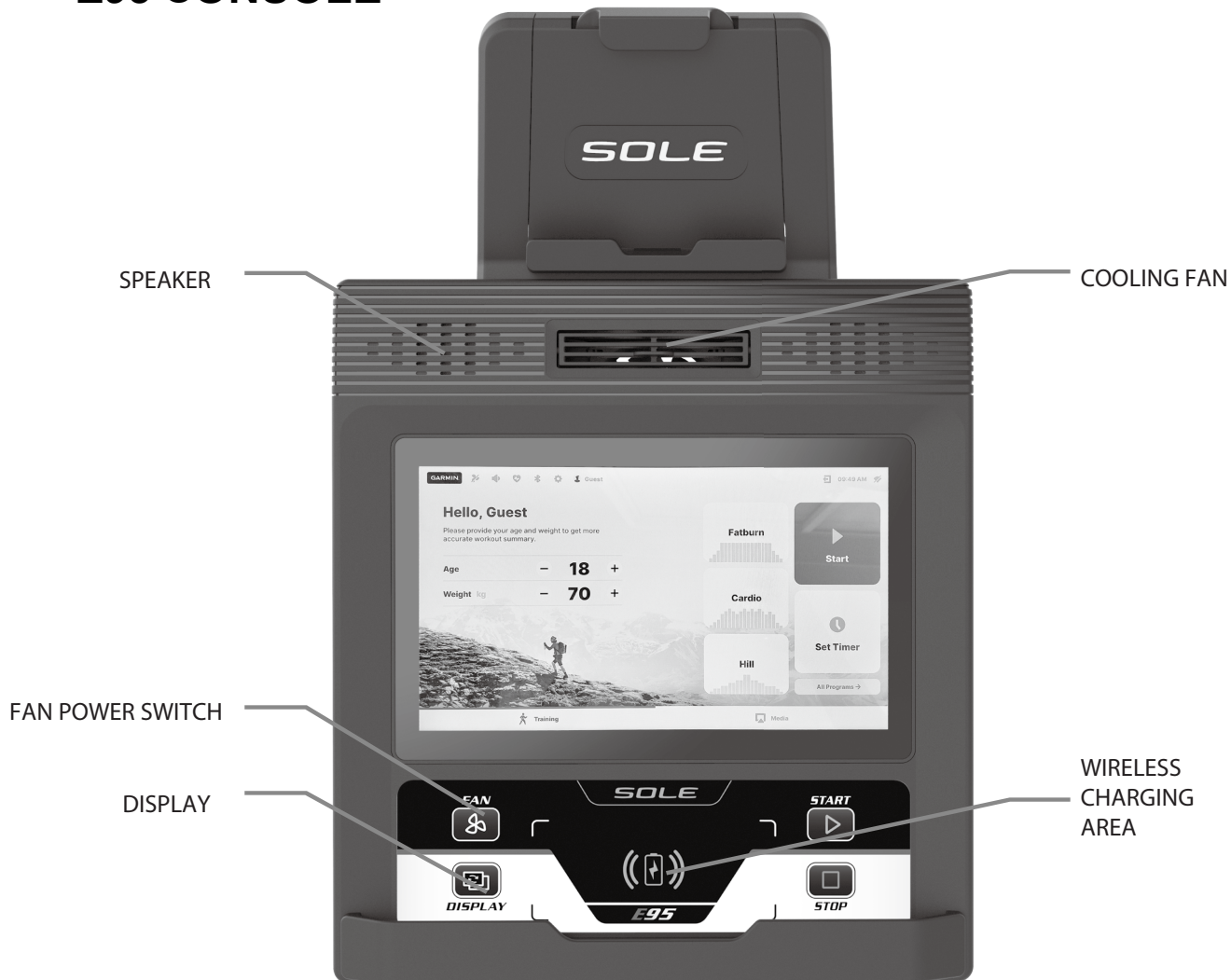

POWER UP

When power is connected to the elliptical, the console will automatically power up. This model is connected directly to 115 VAC and there is a power switch located where the line cord plugs into the unit on the left side near the front.

ATTENTION

SLEEP MODE Your console comes in "Sleep mode" with different features by choice:

ON The unit goes energy-saving state after 15 minutes of inactivity.

OFF The console will stay lit while the power is on.

RETAIL The console will run the demo video after 3 minutes of inactivity.

On TFT displays, click "Sleep Mode" under Settings to switch among three features.

CONSOLE OPERATION

BASIC INFORMATION

The Elliptical has a built-in heart rate monitoring system. Simply grasp the **Contact Heart Rate Sensors** on the stationary handlebars or wear the chest strap transmitter. This may take a few seconds. The **Pulse Window** will display your heart rate in beats per minute. The chest strap is a more accurate and reliable method of heart rate reading. The hand pulse sensors are subject to false readings depending on user physiology and workout habits including how one grips the sensors or how sweaty their hands are.

A message about Calories: Calorie readings on every piece of exercise equipment, whether it is in a gym or at home, are not accurate and tend to vary widely. They are meant only as a guide to monitor your progress from workout to workout. The only way to accurately measure your calorie burn is in a clinical setting connected to a host of machines. This is because every person is different and burns calories at a different rate.

STOP KEY

The **Stop** button has several functions.

Pressing the **Stop** key once during a program will **Pause** the program. If you need to get a drink, answer the phone or any of the many things that could interrupt your workout, this is a great feature. To resume your workout during **Pause**, just press the **Start** key. If the **Stop** button is pressed twice during a workout the program will end and a **Workout Summary** will be displayed.

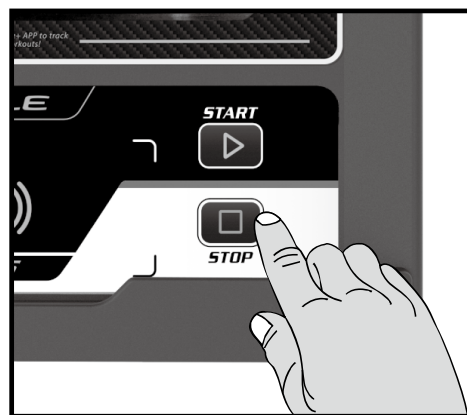

New SOLE + App to be used in conjunction with select Apple & Android devices!

In order to help you achieve your exercise goals, Sole has added an exciting new feature to this product. Your new exercise machine comes equipped with a Bluetooth® transceiver that will allow it to interact with compatible iOS and Android smartphones or tablet computers via the SOLE+ App.

Just download the free SOLE+ App from the Apple Store or Google Play, and follow the instructions in the App to sync with your exercise machine.

The Sole+ App also allows you to sync your workout data with one of many fitness cloud sites we support Apple Health, Google Fit, Strava, MapMyFitness or Fitbit, with more to come.

Syncing the App with your exercise machine:

After downloading the App, make sure Bluetooth® is enabled on your device, then tap the icon at the top right corner to search for Sole equipment.

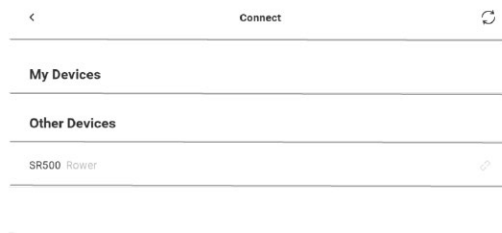
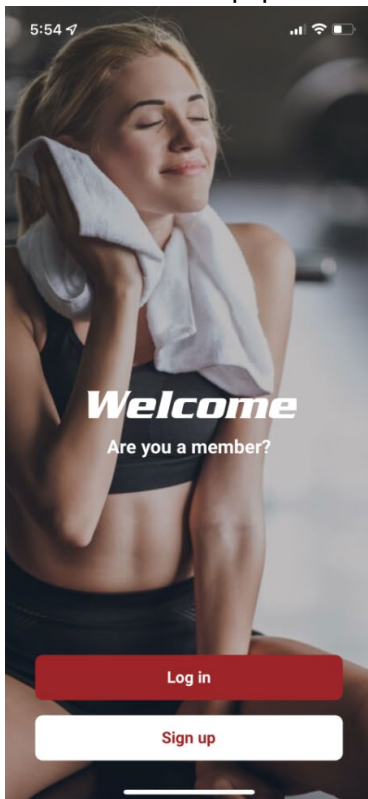

After the equipment is detected, tap Connect. When the App and equipment are synced, the Bluetooth® icon on the equipment's console will light up. You may now start using your new Sole product!

Exercise equipment's Bluetooth device can also be connected to a Bluetooth wireless heart rate chest strap transmitter. Chest Strap transmitter can still connect to the exercise equipment even though the App has already been connected to the exercise equipment.

The exercise equipment can also play music wirelessly via Bluetooth. Turn on your mobile phone or tablet's Bluetooth function. Search for the name "Bt-speaker" in your device's Bluetooth menu. Tap to connect. Now your device can transmit music to the exercise equipment.

Touchscreen Operation

Use the touchscreen console to select from a variety of preset workout programs and fitness tests, and to enjoy media content of your choice while on the go.

The User Interface (UI) images in the manual reflect the version of the software when the product was produced. The software version may be updated occasionally to include new features or repair any bugs when connected to the internet. These updates may change the UI images on the console and may no longer match the manual images.

Getting Started

Launched for the first time, the console will prompt you to either enter as a guest or create a new profile. It is recommended to set up your profile: it allows your machine to remember your physical parameters, favourite programs and templates; you will have your custom program with an adjustable intensity pattern, and your workout records can be synchronized with the SOLE+ mobile app. Tap + to create a new profile. A maximum of 9 profiles can be created. Each profile can be protected with a passcode.

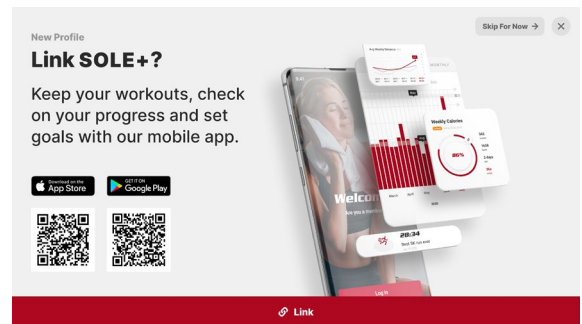
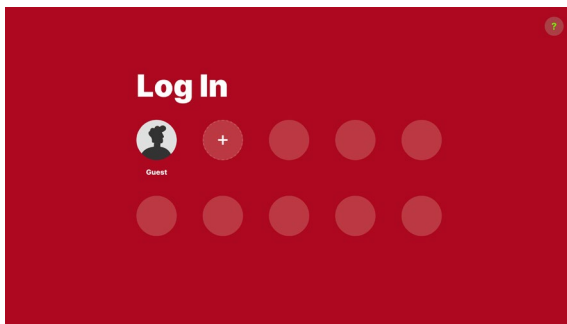

To link a SOLE+ account, scan the QR code on the console screen to download the mobile app first. Once the app is installed and the registration is complete, press “Link” on the bottom of the console screen, then open the QR code scanning camera in your SOLE+ app and scan the QR code once again to link your local profile with the SOLE+ account. Please keep in mind that your console profile cannot be linked to multiple SOLE+ accounts at the same time. If you skip this step, you can access it again later in Profile settings.

Home Screen

The main screen of the Training section displays an overview of your activity and offers shortcuts to the most frequently used training modes: an immediate Start, a manually controlled timed workout (“Timer”), and up to 6 programs that you have marked as your favourites are arranged on this page for your quick access.

If in the Guest mode, you can set your age and weight here; it will help the machine calculate your workout summary more accurately.

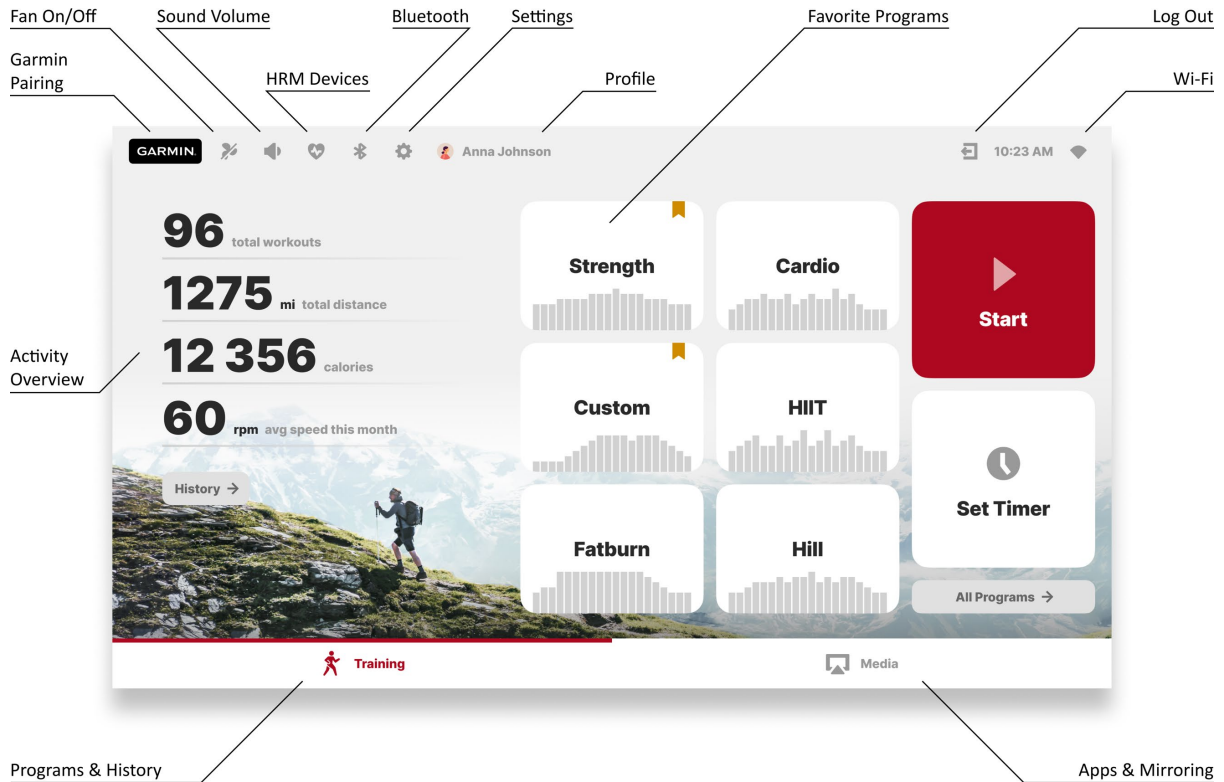

Workout Programs

To access all available categories of programs, press “All Programs” on the Home screen. Once inside, you can use tabs on the top of the screen to switch between All Programs, Templates and Favorites.

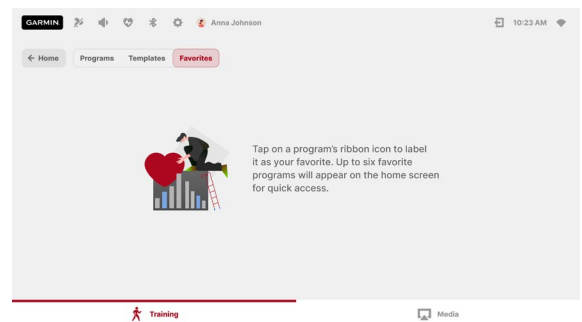
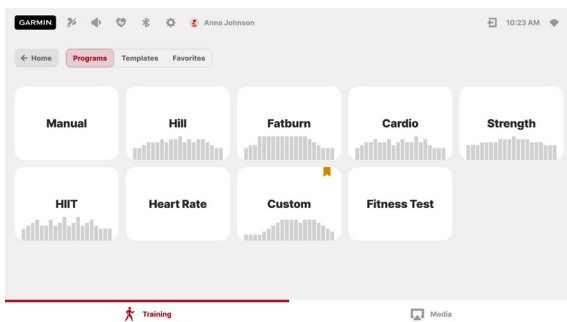

Tap on any of the program cards to open a Program Setup page, where you can learn more about the program, set properties of your workout, or keep browsing by pressing the arrow buttons in the upper top right corner of the screen. To adjust workout parameters, you can drag the ruler, tap on the + and – buttons, or tap on the number to open a numpad and input the value directly.

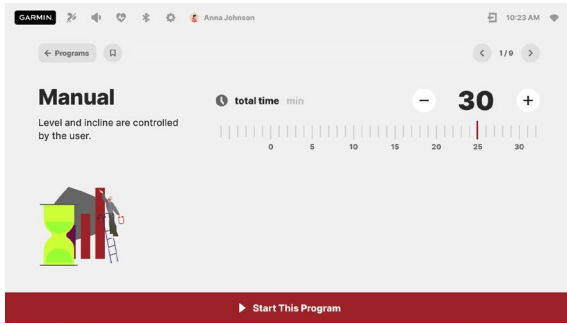

Manual (Timer) program is a timed workout with resistance level and incline controlled manually at any time during the workout.

Hill, Fatburn, Cardio, Strength and **HIIT** follow preset level and incline changing patterns. The Total Time and Max Level settings define the duration and overall intensity of your workout.

The built-in level of difficulty for each segment is shown in the chart below. However, if you change the maximum level on the program setup page before starting, all segments throughout the program will be adjusted proportionally.

Program	SEG	1	2	3	4	5	6	7	8	9	10	11	12	13	14	15	16	17	18	19	20
Hill	Level	1	2	2	3	3	4	4	5	5	7	7	5	5	4	4	3	3	3	2	1
	Incline	1	1	3	3	3	4	4	4	4	5	5	4	4	4	4	3	3	3	1	1
Fatburn	Level	1	2	3	5	5	5	5	5	5	5	5	5	5	5	5	5	5	3	2	1
	Incline	1	1	3	3	3	3	3	3	3	3	3	3	3	3	3	3	3	3	1	1
Cardio	Level	1	2	3	5	6	7	6	6	6	7	6	5	6	7	6	5	6	5	2	1
	Incline	1	1	5	5	6	2	2	2	6	2	2	2	6	1	1	1	5	1	1	1
Strength	Level	1	2	2	3	3	4	4	5	5	6	7	7	8	8	8	8	8	6	4	1
	Incline	1	1	4	4	4	4	5	5	5	5	5	5	5	5	3	3	3	3	1	1
HIIT	Level	1	2	2	7	7	2	2	7	7	2	2	7	7	2	2	7	7	2	2	1
	Incline	1	1	2	5	5	2	2	5	5	2	2	5	5	2	2	5	5	2	1	1

Heart Rate program uses resistance to control your heart rate. The resistance level gradually increases until you reach your target heart rate, then adjusts automatically to keep you within 5 bpm of your goal. A heart rate monitor is required for this program.

On the program setup page, you can either set the target bpm directly or select 60% or 80% of your age-predicted maximum heart rate, allowing the machine to calculate your target automatically. Choosing the second option, make sure you have let the machine know how old you are, otherwise, the calculations will be based on the default values. The program is finished when the time is up, or if your heart rate is 20% higher than the target.

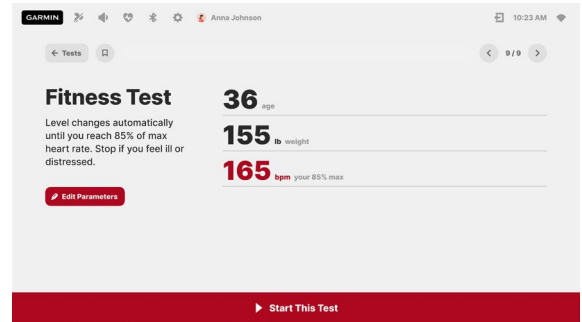
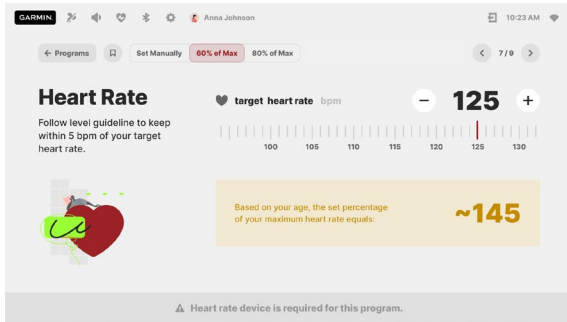

The **Fitness Test** is based on the YMCA Protocol and is a sub-maximal test that uses pre-determined, fixed work levels that are based on your heart rate readings as the test progresses. The test will take anywhere between 6 and 15 minutes to complete, depending on your level of fitness. The test ends when your heart rate reaches 85% of maximum at any time during the test, or if your heart rate is between 110 bpm and 85% at the end of the two consecutive stages. At the end of the test, your VO2 max score will be displayed on the console. VO2 max stands for Volume of Oxygen uptake, which is a measurement of how much oxygen you need to perform a known amount of work.

The YMCA protocol uses two to four 3-minute stages of continuous exercise. On the test setup page, make sure to fix your physical parameters if they are not correct; this information will determine the results of your test.

Before the test,

- make sure you are in good health; check with your physician before performing any exercise if you are over the age of 35 or have any pre-existing health conditions;
- make sure you have warmed up and stretched before taking the test;
- do not take in caffeine before the test.

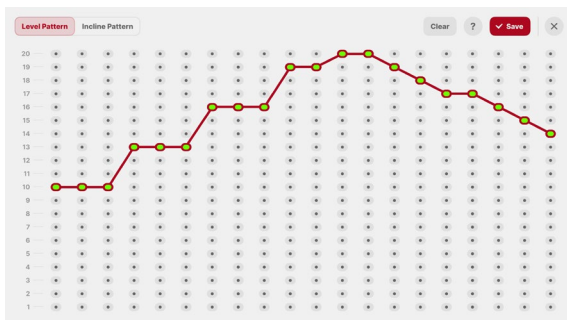

Custom is a program with fully customizable intensity patterns. On the program page, press “Add Pattern” to start editing. Connect dots to map your workload throughout the 20 segments of the program, from the easiest on the bottom to the hardest on the top. Created patterns can be edited later anytime. Each segment’s duration depends on the selected total time — you can set it right before the start.

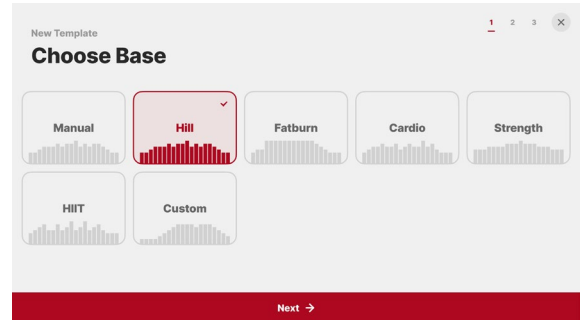
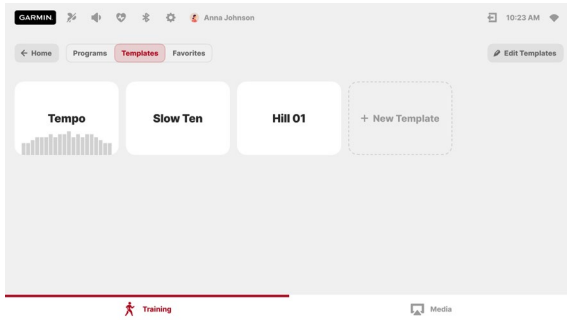

Templates are preset programs with a preserved set of parameters. Programs can be saved as templates upon completion, or you can create one from scratch in the Templates tab: tap on the “New Template” button, choose your base program, and then save it with adjusted properties. A maximum of 12 template programs can be stored. To remove the unwanted templates, press “Edit Templates” in the Templates tab.

A program can be labelled as a **Favorite**. Up to 6 favourite programs will appear right on the Home screen, so you can access them more easily. To “like” a program, open the program setup page and tap on the “ribbon” icon in the upper left corner of the screen. You can find all of the labeled programs under the Favorites tab: to remove the label, press “Edit Favorites”, or go to the program setup page directly and un-tap the “ribbon” icon.

Once you have decided on the program, press the “Start This Program” button on the screen, or the physical “START” key on the machine to begin your workout.

History

To see your latest workout records, press “History” on the main screen of the Training section. Up to 10 records can be stored locally on the console, but you can access your full workout history if you link your profile to the SOLE+ mobile app. Tap on the record preview to see the full summary. Each user can only see his or her workouts.

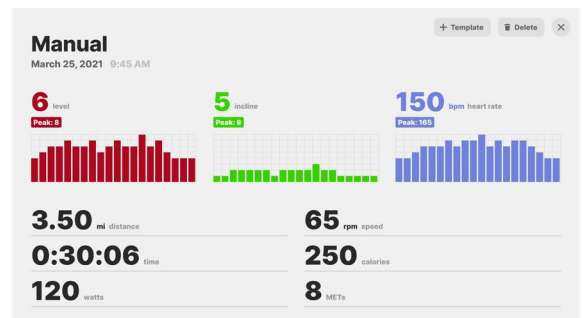
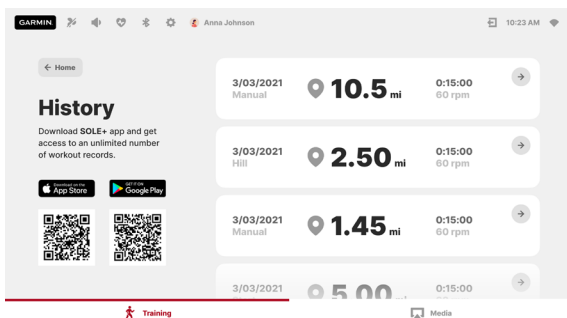

Media

Tap on the right tab of the bottom panel to access the Media section. Choose from a variety of pre-installed third-party **Apps**, or use the **Mirroring** function to cast the content from your smartphone directly to the console screen. For detailed instructions, press the ? icon.

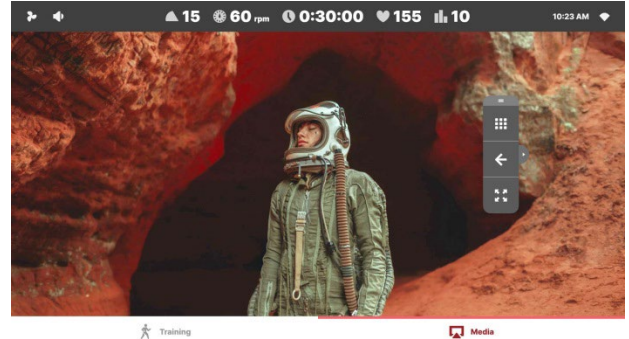
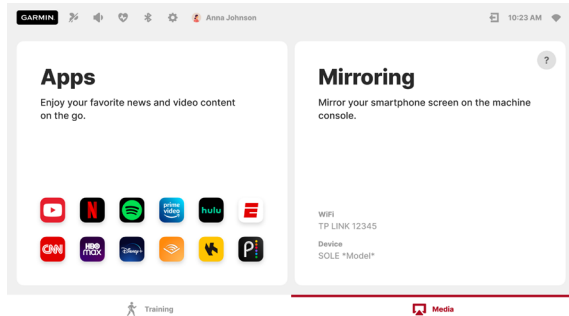

Once the content is on, use the floating panel for navigation and operating full-screen mode. Touch the panel's top edge and drag the panel around the screen to find the perfect place for it, where it will not prevent you from interacting with the content. Press Hide Panels to enter the full-screen mode without stats on the top and tabs on the bottom and Show Panels to bring them back. Use the arrow button on the right side of the panel to hide & show the text labels: it allows you to further minimize the panel's size. Press "Apps" to go back to the content sources selection.

Workout Mode

Once the workout has been started, the console will appear in its workout mode.

During the workout, switch between **Stats**, **Charts** and **Track** views of the Training section, or go to the Media section to enjoy your favourite media content. In the Stats view, you can select the parameters you would like to display by tapping on the number.

Please use physical keys to adjust the level and incline. Press the physical "STOP" key to pause the workout. Here, you can get back to training or end your workout and see the summary. After 5 minutes of inactivity in the Pause mode, the workout will end automatically.

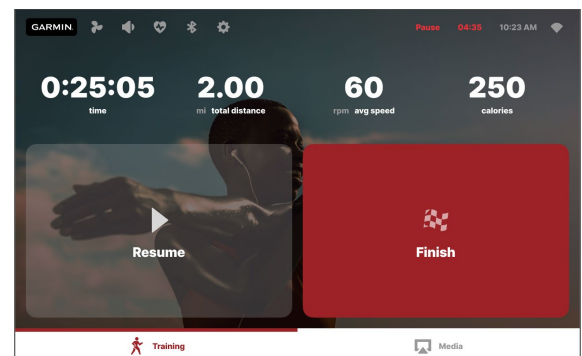
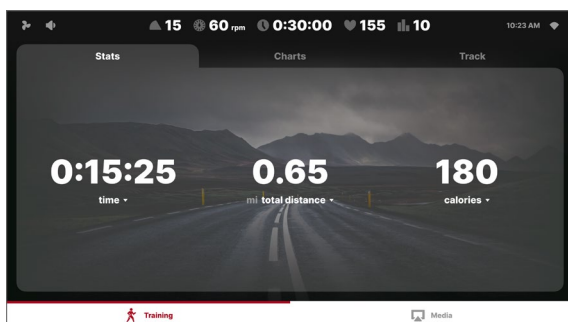

HEART RATE PROGRAMS

Before we get started, a word about Heart Rate:

The old motto, “no pain, no gain”, is a myth that has been overpowered by the benefits of exercising comfortably. A great deal of this success has been promoted by the use of heart rate monitors. With the proper use of a heart rate monitor, many people find that their usual choice of exercise intensity is either too high or too low and exercise is much more enjoyable by maintaining their heart rate in the desired benefit range.

To determine the benefit range in which you wish to train, you must first determine your Maximum Heart Rate. This can be accomplished by using the following formula: 220 minus your age. This will give you the Maximum Heart Rate (MHR) for someone of your age. To determine the effective heart rate range for specific goals you simply calculate a percentage of your MHR. Your Heart rate training zone is 50% to 90% of your maximum heart rate. 60% of your MHR is the zone that burns fat while 80% is for strengthening the cardiovascular system. This 60% to 80% is the zone to stay in for maximum benefit.

For someone who is 40 years old, their target heart rate zone is calculated:

$$\begin{aligned} 220 - 40 &= 180 \text{ (maximum heart rate)} \\ 180 \times .6 &= 108 \text{ beats per minute} \\ &\quad \text{(60\% of maximum)} \\ 180 \times .8 &= 144 \text{ beats per minute} \\ &\quad \text{(80\% of maximum)} \end{aligned}$$

So for a 40-year-old, the training zone would be 108 to 144 beats per minute.

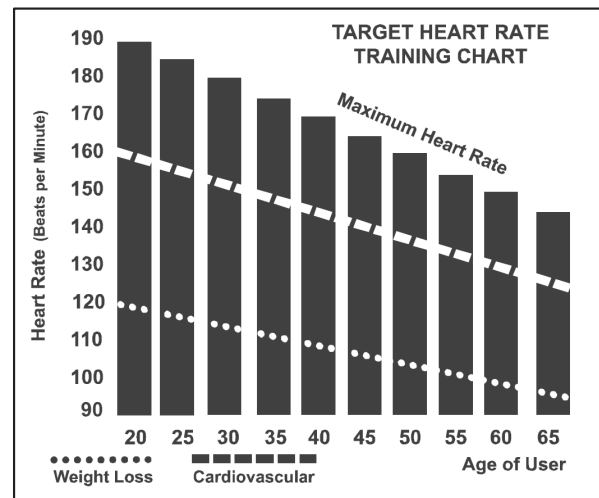

If you enter your age during programming the console will perform this calculation automatically. Entering your age is used for the Heart Rate programs. After calculating your MHR you can decide upon which goal you would like to pursue.

The two most popular reasons for, or goals, of exercise are cardiovascular fitness (training for the heart and lungs) and weight control. The black columns on the chart above represent the MHR for a person whose age is listed at the bottom of each column. The training heart rate, for either cardiovascular fitness or weight loss, is represented by two different lines that cut diagonally through the chart. A definition of the lines' goal is in the bottom left-hand corner of the chart. If your goal is cardiovascular fitness or if it is weight loss, it can be achieved by training at 80% or 60%, respectively, of your MHR on a schedule approved by your physician. Consult your physician before participating in any exercise program.

With all SOLE Heart Rate elliptical machines, you may use the heart rate monitor feature without using the Heart Rate program. This function can be used during manual mode or any of the nine different programs. The Heart Rate program automatically controls resistance at the pedals.

RATE OF PERCEIVED EXERTION

Heart rate is important but listening to your body also has a lot of advantages. There are more variables involved in how hard you should work than just heart rate. Your stress level, physical health, emotional health, temperature, humidity, the time of day, the last time you ate and what you ate, all contribute to the intensity at which you should workout. If you listen to your body, it will tell you all of these things.

The rate of perceived exertion (RPE), also known as the Borg scale, was developed by Swedish physiologist G.A.V. Borg. This scale rates exercise intensity from 6 to 20 depending upon how you feel or the perception of your effort.

The scale is as follows:

Rating Perception of Effort

- 6 Minimal
- 7 Very,very light
- 8 Very,very light +
- 9 Very light
- 10 Very light +
- 11 Fairly light
- 12 Comfortable
- 13 Somewhat hard
- 14 Somewhat hard +
- 15 Hard
- 16 Hard +
- 17 Very hard
- 18 Very hard +
- 19 Very,very hard
- 20 Maximal

You can get an approximate heart rate level for each rating by simply adding a zero to each rating. For example, a rating of 12 will result in an approximate heart rate of 120 beats per minute. Your RPE will vary depending on the factors discussed earlier. That is the major benefit of this type of training. If your body is strong and rested, you will feel strong, and your pace will feel easier. When your body is in this condition, you can train harder and the RPE will support this. If you are feeling tired and sluggish, it is because your body needs a break. In this condition, your pace will feel harder. Again, this will show up in your RPE and you will train at the proper level for that day.

USING HEART RATE TRANSMITTER (OPTIONAL)

How to wear your wireless chest strap transmitter:

1. Attach the transmitter to the elastic strap using the locking parts.
2. Adjust the strap as tightly as possible as long as the strap is not too tight to remain comfortable.
3. Position the transmitter with the SOLE logo centered in the middle of your body facing away from your chest (some people must position the transmitter slightly left of center). Attach the end of the elastic strap by inserting the round end and, using the locking parts, secure the transmitter and strap around your chest.
4. Position the transmitter immediately below the pectoral muscles.
5. Sweat is the best conductor to measure very minute heartbeat electrical signals. However, plain water can also be used to pre-wet the electrodes (2 ribbed oval areas on the reverse side of the belt and both sides of the transmitter). It's also recommended that you wear the transmitter strap a few minutes before your workout. Some users, because of body chemistry, have a more difficult time achieving a strong, steady signal at the beginning. After "warming up", this problem lessens. As noted, wearing clothing over the transmitter/strap doesn't affect performance.
6. Your workout must be within range - distance between transmitter/receiver - to achieve a strong steady signal. The length of range may vary somewhat but generally stay close enough to the console to maintain good, strong, reliable readings. Wearing the transmitter immediately against bare skin assures you of proper operation. If you wish, you may wear the transmitter over a shirt. To do so, moisten the areas of the shirt that the electrodes will rest upon.

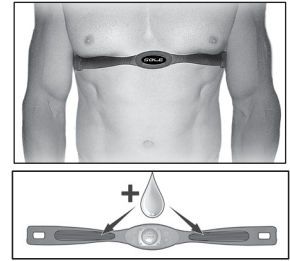

Note: The transmitter is automatically activated when it detects activity from the user's heart. Additionally, it automatically deactivates when it does not receive any activity. Although the transmitter is water resistant, moisture can have the effect of creating false signals, so you should take precautions to completely dry the transmitter after use to prolong battery life (estimated transmitter battery life is 2500 hours). The replacement battery is Panasonic CR2032.

ERRATIC OPERATION

Caution! Do not use this elliptical for Heart Rate unless a steady, solid Actual Heart Rate value is being displayed. High, wild, random numbers being displayed indicate a problem.

Areas to look for interference which may cause erratic heart rate:

1. Microwave ovens, TV's, small appliances, etc.
2. Fluorescent lights.
3. Some household security systems.
4. Perimeter fence for a pet.
5. Some people have problems with the transmitter picking up a signal from their skin. If you have problems, try wearing the transmitter upside down. Normally the transmitter will be oriented so the SOLE logo is right side up.
6. The antenna that picks up your heart rate is very sensitive. If there is an outside noise source, turning the whole machine 90 degrees may de-tune the interference.
7. Another Individual wearing a transmitter within 3' of your machine's console.

If you continue to experience problems, contact your dealer.

GENERAL MAINTENANCE

1. Wipe down all areas in the sweat path with a damp cloth after each workout.
2. If a squeak, thump, clicking or rough feeling develops the main cause is most likely one of two reasons:
 - I. The hardware was not sufficiently tightened during assembly. All bolts that were installed during assembly need to be tightened as much as possible. It may be necessary to use a larger wrench than the one provided if you cannot tighten the bolts sufficiently. I cannot stress this point enough; 90% of calls to the service department for noise issues can be traced to loose hardware or the rear rails being dirty.
 - II. Dirt build-up on the rear rails and polyurethane wheels are also a source of noise. Noise from build-up on the rails can cause a thumping sound that you would swear is coming from inside the main body of the machine because noise travels and is amplified in the tubing of the frame. Clean the rails and wheels with a lint-free cloth and rubbing alcohol. Stubborn build-up can be removed with your thumbnail or a non-metallic scraper, like the back edge of a plastic knife. After cleaning, apply a small amount of lubricant on the rails with your fingers or a lint-free cloth. You only need a thin coat of lubrication, to wipe off any excess.
3. If squeaks or other noises persist, check that the unit is properly levelled before calling the service department.

PARTS LIST

Key	Part Description	Q'ty
1	Main Frame	1
2	Incline Rail Assembly	1
3	Console Holder Assembly	1
4	Cross Bar	2
5	Bushing Housing, Pedal Arm	2
6	Pedal Arm (L)	1
7	Pedal Arm (R)	1
8	Pedal Bar Assembly (L)	1
9	Pedal Bar Assembly (R)	1
10	Lower Handlebar (L)	1
11	Lower Handlebar (R)	1
12	Console Mast	1
13	Idler Bracket	1
14	Crank Axle	1
15	Handpulse Assembly (L)	1
16	Handpulse Assembly (R)	1
17	Rear Rail Assembly	1
18	Joint	1
19	Top Handlebar (L)	1
20	Top Handlebar (R)	1
21	Adjustable Pedal	2
22	Pedal Adjustment Assembly	2
23	Cover Holder(B)	2
24	Controller Fixing Plate	1
25	Fixing Axle	4
26	Ø38 × Ø8.5 × 4T Flat Washer	2
27	Rod End Sleeve	3
28	Axle	2
29	Adjusting Plate	4
30	Aluminum Rail	4
31	6005 Bearing	5
32	6005-2RSB10+2M5 Bearing	1
33	6003 Bearing	4
34	6203 Bearing	2
35	M12 × P1.75 Rod End Bearing	2
36	Drive Belt	1
37	Flywheel	1
38	Magnet	1
39	Steel Cable	1
40	Handgrip Resistance Label (INCLINE)	1
41	Handgrip Resistance Label (LEVEL)	1
42	Pedal Adjustment Knob	2
45	Console Assembly	1
45-01	Console Top Cover	1
45-02	Console Bottom Cover	1

Key	Part Description	Q'ty
45-03	Deflector Fan Grill	1
45-04	Wind Duct (L)	1
45-05	Wind Duct (R)	1
45-06	Electronic Fixing Plate	1
45-07	Book Rack	1
45-08	Fan Grill Anchor	2
45-09	Speaker Grill Anchor	6
45-11	Console Display Board	1
45-12	Main Keyboard	1
45-13	400m/m Fan Assembly (White)	1
45-14	350m/m Speaker W/Cable	2
45-16	300m/m W/Receiver, HR	1
45-17	Wireless Charger Module	1
45-18	Interface Board	1
45-19	350m/m Keyboard	1
46	450m/m Connecting Wire (White)	1
46-01	450m/m Connecting Wire (Black)	1
47	550m/m Computer Cable	1
48	900m/m Incline Motor Power Wire	1
49	850m/m Connecting Wire, Incline Motor	1
50	1600m/m Computer Cable	1
51	AC Electronic Module	1
52	80m/m Connecting Wire (White)	1
53	200m/m Ground Wire	1
53-01	250m/m Ground Wire	1
54	Gear Motor	1
55	600m/m Sensor W/Cable	1
56	Incline Motor	1
57	850m/m Handpulse W/Cable Assembly (Red)	1
58	850m/m Handpulse W/Cable Assembly-White	1
59	Power Cord	1
60	Resistance Button W/Cable	2
61	450m/m Handle Wire (Upper), Resistance	1
62	450m/m Handle Wire (Upper), Incline	1
63	900m/m Handle Wire, Resistance/Incline	2
64	Incline Controller	1
67	80m/m Connecting Wire (Black)	1
68	Filter	1
69	450m/m Connecting Wire (White)	1
69-01	450m/m Connecting Wire (Black)	1
70	Oval End Cap	2
71	Switch Wire Cap	2
72	32 × 2.5T Round Cap	4
73	∅32 × 1.8T Round Cap	2
74	Transportation Wheel	2
75	Drive Pulley	1

Key	Part Description	Q'ty
76	Oval End Cap	2
77	Bushing	8
78	Rubber Foot Pad	3
79	Button Head Plug	2
80	3/8" × 35 × 5T Nylon Washer	2
81	5/16" × 25 × 3T Nylon Washer	2
82	Ø25 × 25mm Rubber Foot Pad	1
83	Threaded Bushing	2
84	Rubber Pad	1
85	Protection Cap	1
86	Round Bushing	2
87	Handle Switch Bracket	2
88	WFM-2528-21 Bushing	4
89	Tablet Holder Assembly	1
90	Adjustment Foot	6
91	Sliding Wheel Urethane	4
92	Drink Bottle Holder	1
93	Pedal Arm Cover (L)	1
94	Pedal Arm Cover (R)	1
95	Slide Wheel Cover	2
96	Pedal (L)	1
97	Pedal (R)	1
98	Pedal Foam (L)	1
99	Pedal Foam (R)	1
100	Console Mast Cover (L)	1
101	Console Mast Cover (R)	1
102	Chain Cover (L)	1
103	Chain Cover (R)	1
104	Round Disk	2
105	Round Disk	2
106	Front Handlebar Cover (L)	1
107	Rear Handlebar Cover (L)	1
108	Front Handlebar Cover (R)	1
109	Rear Handlebar Cover (R)	1
110	Pedal End Cover	2
111	Ø14 × Ø10 × 9T Bushing	4
112	Front Stabilizer Cover	1
113	Bottom Cover	1
114	Incline Cover	1
115	Inclinable Rail Cover	1
116	Rear Bar Cover	1
117	16.1 × 31 × 3T Nylon Washer	2
118	Connecting Arm Cover A (R)	2
119	Connecting Arm Cover A (L)	2
120	Connecting Arm Cover B (R)	2
121	Connecting Arm Cover B (L)	2

Key	Part Description	Q'ty
125	1/4" × UNC20 × 3/4" Hex Head Bolt	4
126	5/16" × 1" Hex Head Bolt	2
127	5/16" × 15mm Hex Head Bolt	16
128	5/16" × 1-1/4" Hex Head Bolt	2
129	5/16" × UNC18 × 2-1/2" Hex Head Bolt	1
130	3/8" × 3/4" Hex Head Bolt (electric black)	10
131	3/8" × 3/4" Hex Head Bolt	2
132	3/8" × 2" Hex Head Bolt	4
133	3/8" × 2-1/4" Hex Head Bolt	6
134	3/8" × 2-1/2" Hex Head Bolt	1
135	M10 × P1.5 × 90L Hex Head Bolt	1
136	M10 × 40mm Hex Head Bolt	4
137	M8 × 1.25 × 40mm Socket Head Cap Bolt	2
138	3/8" × 3/4" Socket Head Cap Bolt	6
139	3/8" × 2-1/4" Socket Head Cap Bolt	2
140	5/16" × 2" Button Head Socket Bolt	2
141	M4 × 12mm Phillips Head Screw	2
142	M5 × 10mm Phillips Head Screw	8
143	M5 × 10mm Phillips Head Screw	42
144	5 × 16mm Tapping Screw	12
145	5 × 19mm Tapping Screw	21
146	3.5 × 12mm Sheet Metal Screw	24
147	3.5 × 16mm Sheet Metal Screw	10
148	M6 × 10mm Phillips Head Screw	4
149	3 × 20mm Tapping Screw	4
150	M5 × 15mm Flat Head Socket Screw	4
151	Ø25 C Ring	4
152	Ø17 C Ring	5
153	E12 E-Clip (Blackfast)	2
154	M4 × P0.7 × 5T Nylon Nut	2
155	1/4" × 8T Nylon Nut	4
156	5/16" × 7T Nylon Nut	5
157	M8 × 7T Nylon Nut	1
158	M8 × 9T Nylon Nut	1
159	3/8" × 7T Nylon Nut	15
160	3/8" × 11T Nylon Nut	2
161	M10 × 8T Nylon Nut	5
162	3/8" × UNF26 × 4T Nut	2
163	3/8" × UNF26 × 11T Nut	2
164	M8 × 6.3T Nut	4
165	Ø1/4" × 19mm Flat Washer	13
166	Ø5/16" × Ø20 × 1.5T Flat Washer	6
167	Ø5/16" × Ø23 × 1.5T Flat Washer	6
168	Ø5/16" × Ø23 × 3T Flat Washer	4
169	Ø5/16" × 35 × 2.0T Flat Washer	4
170	Ø3/8" × Ø19 × 1.5T Flat Washer	40

Key	Part Description	Q'ty
171	Ø3/8" × 30 × 2.0T Flat Washer	2
172	Ø17 × Ø23.5 × 1.0T Flat Washer	1
173	Ø3/8" × 23 × 2.0T Curved Washer	4
174	Ø10 × 2T Split Washer	10
175	M8 × 130mm J Bolt	1
176	M8 × 20mm Carriage Bolt	1
177	Woodruff Key	2
180	Short Phillips Head Screwdriver	1
181	Phillips Head Screwdriver	1
182	L Allen Wrench	1
183	13/14m/m Wrench	1
184	12/14m/m Wrench	1
195	Ø10 Star Washer	4
196	Side Back	1

MANUFACTURER'S LIMITED WARRANTY

ELLIPTICAL WARRANTY

Dyaco Canada Inc. warrants all its Sole elliptical parts, for a period listed below, from the date of retail sale, as determined by a sales receipt. Dyaco Canada Inc.'s responsibilities include providing new or remanufactured parts, at Dyaco Canada Inc.'s option, and technical support to our independent dealers and servicing organizations. In the absence of a dealer or service organization, these warranties will be administered by Dyaco Canada Inc. directly to a consumer. The warranty period applies to the following components:

Frame	Lifetime
Parts	2 Years
Labour	1 Year

NORMAL RESPONSIBILITIES OF THE CONSUMER

This warranty applies only to products in ordinary household use, and the consumer is responsible for the items listed below:

1. The warranty registration can be completed online: Go to www.dyaco.ca/warranty and complete the online warranty registration.
2. Proper use of the elliptical by the instructions provided in this manual.
3. Proper installation by the instructions provided with the elliptical and with all local electric codes.
4. Proper connection to a grounded power supply of sufficient voltage, replacement of blown fuses, repair of loose connections or defects in house wiring.
5. Expenses for making the elliptical accessible for servicing, including any item that was not part of the elliptical at the time it was shipped from the factory.
6. Damages to the elliptical finish during shipping, installation or following installation.
7. Routine maintenance of this unit as specified in this manual.

EXCLUSIONS

This warranty does not cover the following:

1. CONSEQUENTIAL, COLLATERAL, OR INCIDENTAL DAMAGES SUCH AS PROPERTY DAMAGE AND INCIDENTAL EXPENSES RESULTING FROM ANY BREACH OF THIS WRITTEN OR IMPLIED WARRANTY.
Note: Some areas do not allow the exclusion or limitation of incidental or consequential damages, so this limitation or exclusion may not apply to you.
2. Service call reimbursement to the consumer. Service call reimbursement to the dealer that does not involve malfunction or defects in workmanship or material, for units that are beyond the warranty period, for units that are beyond the service call reimbursement period, for ellipticals not requiring component replacement, or ellipticals not in ordinary household use.
3. Damages caused by services performed by persons other than authorized Dyaco Canada Inc. service companies; use of parts other than original Dyaco Canada Inc. parts; or external causes such as corrosion, discoloration of paint or plastic, alterations, modifications, abuse, misuse, accident, improper maintenance, inadequate power supply, or acts of God.
4. Products with original serial numbers that have been removed or altered.
5. Products that have been: sold, transferred, bartered, or given to a third party.
6. Products that do not have a warranty registration card on file at Dyaco Canada Inc. Dyaco Canada Inc. reserves the right to request proof of purchase if no warranty record exists for the product.
7. THIS WARRANTY IS EXPRESSLY INSTEAD OF ALL OTHER WARRANTIES EXPRESSED OR IMPLIED, INCLUDING THE WARRANTIES OF MERCHANTABILITY AND/OR FITNESS FOR A PARTICULAR PURPOSE.
8. Product use in any environment other than a residential setting.
9. Warranties outside of North America may vary. Please contact your local dealer for details.

SERVICE

Keep your bill of sale. The labour warranty period is twenty-four (24) months from the date on the bill of sale. If service is performed, it is in your best interest to obtain and keep all receipts. This written warranty gives you specific legal rights. You may also have other rights that vary in different areas. Service under this warranty must be obtained by following these steps, in order:

1. Contact your selling authorized SOLE dealer.
2. If you have any questions about your new product or questions about the warranty contact Dyaco Canada Inc. at 1-888-707-1880.
3. If no local service is available, Dyaco Canada Inc. will repair or replace the parts, at Dyaco Canada Inc.'s option, within the warranty period at no charge for parts. All transportation costs, both to our factory and upon return to the owner, are the responsibility of the owner.
The owner is responsible for adequate packaging upon return to Dyaco Canada Inc. Dyaco Canada Inc. is not responsible for damages that occur during shipping. Make all freight damage claims with the appropriate freight carrier. DO NOT SHIP ANY UNIT TO OUR FACTORY WITHOUT A RETURN AUTHORIZATION NUMBER. All units arriving without a return authorization number will be refused.
4. For any further information, or to contact our service department by mail, send your correspondence to:

Dyaco Canada Inc.
5955 Don Murie Street
Niagara Falls, ON
L2G 0A9

Product features or specifications as described or illustrated are subject to change without notice. All warranties are made by Dyaco Canada Inc.

dyaco

Please visit us online for information about our other brands and products, manufactured and distributed by Dyaco Canada Inc.

SPIRIT

spiritfitness.ca

SOLE
FITNESS

solefitness.ca

X XTERRA

xterrafitness.ca

EVERLAST

dyaco.ca/products/everlast.html

UFC

dyaco.ca/UFC/UFC-home.html

Johnny G
by SPIRIT

spiritfitness.ca/johnnyg.html

TRINOR
SPORTS

trainorsports.ca

For more information, please contact Dyaco Canada Inc.
T: 1-888-707-1880 | 5955 Don Murie St., Niagara Falls, Ontario L2G 0A9 | sales@dyaco.ca

Dyaco Canada Inc. dyaco.ca

SOLE[™]
FITNESS