

SOLE
FITNESS

OWNER'S MANUAL
Model: 16808533000
SR300 Air/Magnetic
Rowing Machine

**Please carefully read this entire manual
before operating your new rower.**

ATTENTION: *Before returning your SOLE product to any retailer, or if you require any assistance with assembly or technical support please call us first for assistance at 1-888-707-1880. Thank you for your SOLE purchase.*

TABLE OF CONTENTS

<u>Product Registration</u>	3
<u>Before You Begin</u>	4
<u>Important Safety Instructions</u>	5
<u>Important Operation Instructions</u>	6
<u>SR300 Assembly Instructions</u>	7
<u>Operation of Your New Air Indoor Cycle</u>	23
<u>Troubleshooting</u>	29
<u>Training Guidelines</u>	32
<u>Exploded View Drawing</u>	36
<u>Parts list</u>	37
<u>Manufacturer's Limited Warranty</u>	41

ATTENTION

THIS FITNESS EQUIPMENT IS INTENDED FOR **RESIDENTIAL USE ONLY** AND IS WARRANTED FOR THE APPLICATION. ANY OTHER APPLICATION **VOIDS** THIS WARRANTY IN ITS ENTIRETY.

SOLE

FITNESS

CONGRATULATIONS ON YOUR NEW AIR/MAGNETIC ROWER AND WELCOME TO THE SOLE FAMILY!

Thank you for your purchase of this quality SOLE equipment from Dyaco Canada Inc. Your new rower has been manufactured by one of the leading fitness manufacturers in the world and is backed by one of the most comprehensive warranties available. Dyaco Canada Inc. will do all we can to make your ownership experience as pleasant as possible for many years to come.

If you have any questions about your new SOLE product or questions about the warranty contact Dyaco Canada Inc. at 1-888-707-1880.

Please take a moment at this time to record below the name of the dealer, their telephone number, and the date of purchase for easy contact in the future. We appreciate your confidence in SOLE and we will always remember that you are the reason that we are in business.

Please go to www.dyaco.ca/warranty.html and complete the online warranty registration.

Yours in Health,

Dyaco Canada Inc.

Name of Dealer _____

Telephone Number of Dealer _____

Purchase Date _____

PRODUCT REGISTRATION

RECORD YOUR SERIAL NUMBER

Please record the Serial Number of this fitness product in the space provided below.

Serial Number _____

BEFORE YOU BEGIN

Thank you for choosing the SOLE SR300 Air/Magnetic Rowing Machine. We take great pride in producing this quality product and hope it will provide many hours of quality exercise to make you feel better, look better, and enjoy life to its fullest. It's a proven fact that a regular exercise program can improve your physical and mental health. Too often, our busy lifestyles limit our time and opportunity to exercise. The SOLE SR300 Air/Magnetic Rowing Machine provides a convenient and simple method to begin your assault on getting your body in shape and achieving a happier and healthier lifestyle. Before reading further, please review the drawing below and familiarize yourself with the parts that are labelled.

Read this manual carefully before using the SOLE SR300 Air/Magnetic Rowing Machine. Although Dyaco Canada Inc. constructs its products with the finest materials and uses the highest standards of manufacturing and quality control, there can sometimes be missing parts or incorrectly sized parts. If you have any questions or problems with the parts included with your SOLE SR300 Air/Magnetic Rowing Machine, please do not return the product. Contact us FIRST! If a part is missing or defective, call us toll-free at 1-888-707-1880. Our Customer Service Staff are available to assist you from 8:30 A.M. to 4:30 P.M. (Eastern Time) Monday through Friday. Be sure to have the name and model number of the product available when you contact us.

MAX. USER WEIGHT LIMIT 160 KG (350 LB)

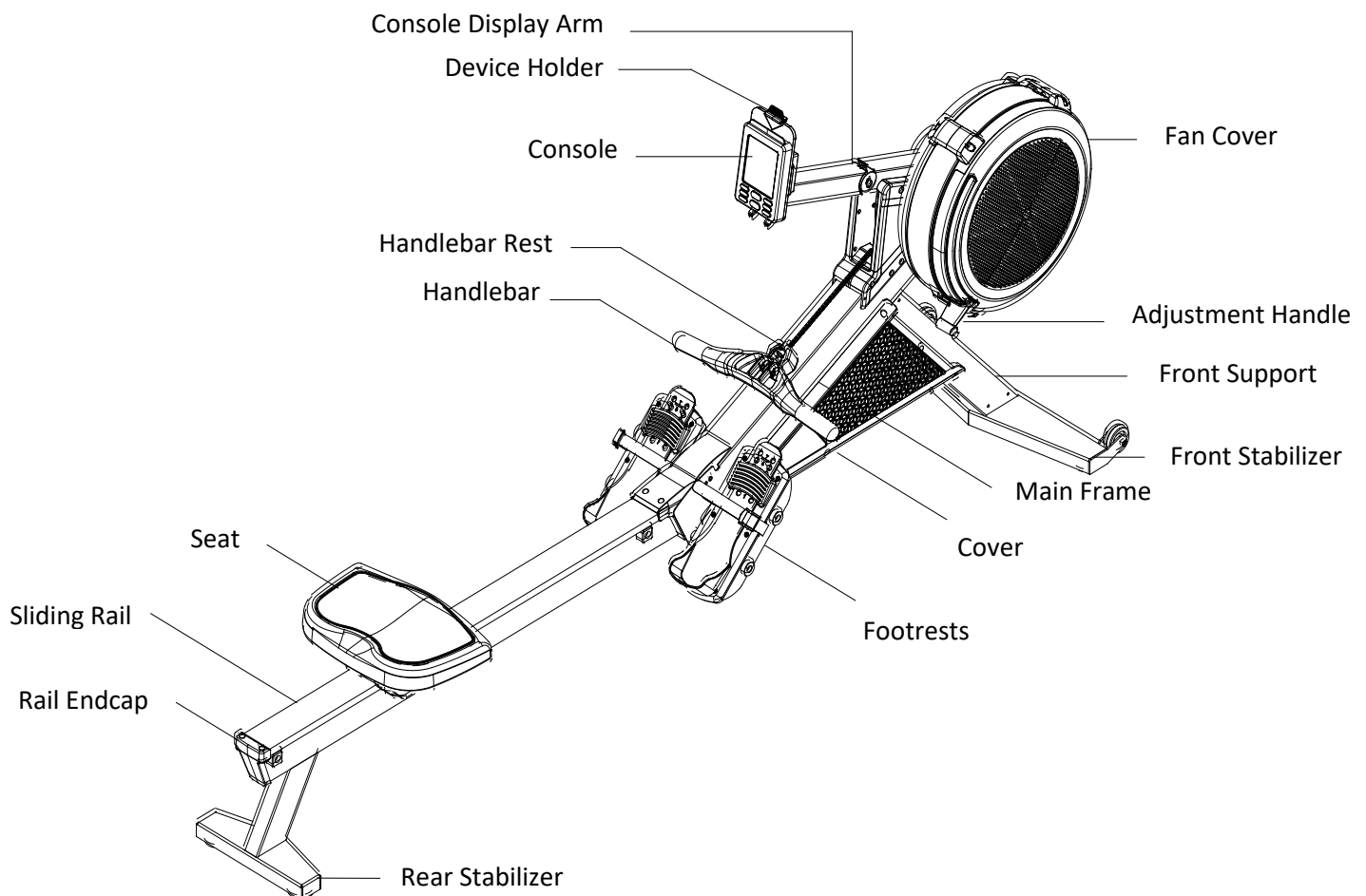

IMPORTANT SAFETY INSTRUCTIONS

WARNING - Read all instructions before using this equipment.

Thank you for purchasing our product. Even though we go to great efforts to ensure the quality of each product we produce, occasional errors and /or omissions do occur. In any event should you find this product to have either a defective or a missing part please contact us for a replacement.

This exercise equipment was designed and built for optimum safety. However, certain precautions apply whenever you operate a piece of exercise equipment. Be sure to read the entire manual before assembly and operation of this machine. Also, please note the following safety precautions:

1. Read the OWNER'S OPERATING MANUAL and all accompanying literature and follow it carefully before using your rower.
2. If dizziness, nausea, chest pains, or any other abnormal symptoms are experienced while using this equipment, STOP the workout at once. CONSULT A PHYSICIAN IMMEDIATELY.
3. Inspect your exercise equipment prior to exercising to ensure that all nuts and bolts are fully tightened before each use.
4. The rower must be regularly checked for signs of wear and damage. Any part found defective must be replaced with a new part from the manufacturer.
5. Fitness equipment must always be installed on a flat surface, It is recommended to use an equipment mat to prevent the unit from moving while it is being used, which could possibly scratch or damage the surface of your floor.
6. No changes must be made which might compromise the safety of the equipment.
7. It is recommended to have a minimum of 2' safe clearance around the exercise equipment while in use.
8. Do not allow children to use or play on the rower. Keep children and pets away from this equipment at all times while exercising.
9. The rower should only be used by one person at a time.
10. Maximum user weight 350lb (160 KG).
11. Warm up 5 to 10 minutes before each workout and cool down 5 to 10 minutes afterward. This allows your heart rate to gradually increase and decrease and will help prevent you from straining muscles.
12. Never hold your breath while exercising. Breathing should remain at a normal rate in conjunction with the level of exercise being performed .
13. Always wear suitable clothing and footwear while exercising. Do not wear loose fitting clothing that could become entangled with the moving parts of your rower.
14. Do not exercise in bare feet or socks. Proper footwear such as running, walking or cross training shoes should be worn.
15. Tie all long hair back. Remove all personal jewelry before exercising.
16. Be careful to maintain your balance while using, mounting, dismounting the rower, loss of balance may result in a fall and bodily injuries.
17. After eating, allow 1-2 hours before exercising as this will help to prevent muscle strain.
18. Injuries may result from incorrect or excessive training and using the equipment other than as directed or recommended by your doctor.
19. Care must be taken when lifting or moving equipment, so as not to injure your back. Always use proper lifting techniques.
20. A decal like the example shown has been placed on the rower. If the decal is missing or illegible, please call our Customer Service Department toll-free at 1-800-707-1880 to order a replacement decal. Apply the decal in the location shown.

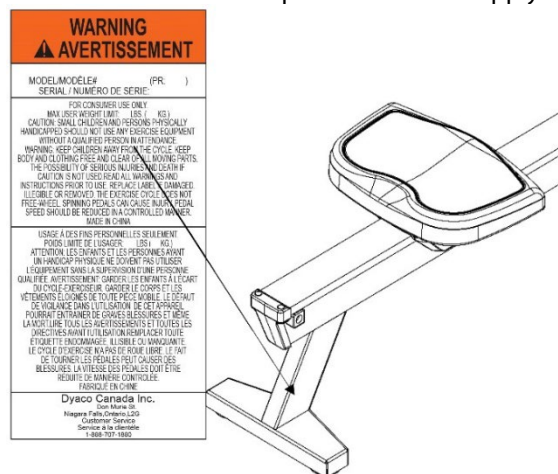

Regularly examine the rower for damage and wear. Inoperable components should be replaced immediately, or the equipment should not be used until it is repaired.

Failure to follow all guidelines may compromise the effectiveness of the exercise experience, expose yourself (and possibly others) to injury, and reduce the longevity of the equipment.

 **WARNING: BEFORE BEGINNING ANY EXERCISE PROGRAM CONSULT YOUR PHYSICIAN. THIS IS ESPECIALLY IMPORTANT FOR INDIVIDUALS OVER THE AGE OF 35 OR PERSONS WITH PRE-EXISTING HEALTH PROBLEMS. READ ALL INSTRUCTIONS BEFORE USING ANY FITNESS EQUIPMENT. WE ASSUME NO RESPONSIBILITY FOR PERSONAL INJURY OR PROPERTY DAMAGE SUSTAINED BY OR THROUGH THE USE OF THIS PRODUCT.**

SAVE THESE INSTRUCTIONS - THINK SAFETY!
CAUTION! Please be careful when unpacking the carton.

IMPORTANT OPERATION INSTRUCTIONS

WARNING - AS THE OWNER OF THIS EXERCISE EQUIPMENT, YOU SHOULD INSIST THAT ALL USERS FOLLOW THE SAME GUIDELINES: YOU SHOULD MAKE THIS MANUAL AVAILABLE TO ALL USERS.

1. Obtain a complete physical examination from your medical doctor and enlist a health/ fitness professional's aid in developing an exercise program suitable for your current health status.
2. When working out for the first time, start out slowly for a minimum of five minutes. After your muscles are warmed up, gradually increase the pedalling speed and/or resistance.
3. The speed and duration of your exercise program should always be subject to how you feel. Never permit peer pressure to exceed your personal judgment while exercising.
4. Overweight or severely de-conditioned individuals should be particularly cautious when using the equipment for the first time. Even though such individuals may not have histories of serious physical problems, they may perceive the exercise to be far less intense than it really is, resulting in the possibility of overexertion or injury.
5. Proper installation and regular maintenance are required to ensure user's safety. Maintenance is the sole responsibility of the owner.

SR300 ASSEMBLY PACK CHECKLIST

Open the packaging and remove the hardware kit, ensuring all listed components are present. Some parts are pre-fitted to the product.

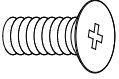
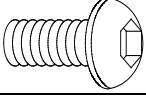

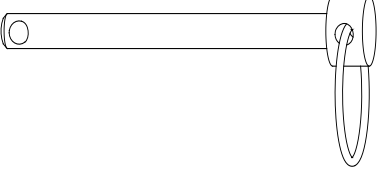

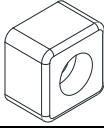

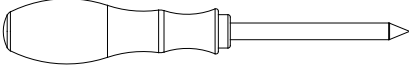
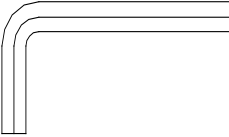
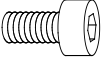

Diagram	Part No.	Description	Qty
	83	Phillips screw (M6 x 16mm)	2
	117	Screw (M8 x 20mm)	1
	76	Washer M6	8
	79	Washer M8	8
	98	Pin	1
	178	Footrest stop block	2
	116	Stopper Bumper	1
	80	Nylon nut M8	1
	102	Screwdriver	2
	103	Allen key 6mm	2
	132	Allen key 5mm	1

Diagram	Part No.	Description	Qty
	99	Allen screw (M6 x 16mm)	8

	165	Phillips screw (M6 x 12mm)	12
	173	Allen screw (M8 x 20mm)	5
	78	Allen screw (M8 x 75mm)	1

SR300 ASSEMBLY INSTRUCTIONS

PRE-ASSEMBLY

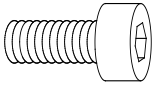
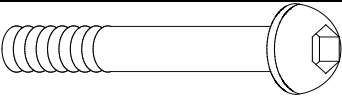
- Carefully remove all parts from carton and inspect for any damage or missing parts. If damaged parts are found or parts are missing, contact your dealer immediately.
- Locate the hardware package. Remove the tools first. Remove the hardware for each step as needed to avoid confusion. The numbers in the instructions that are in parenthesis (#) are the item number from the assembly drawing for reference.

1 REMOVE PACKAGING

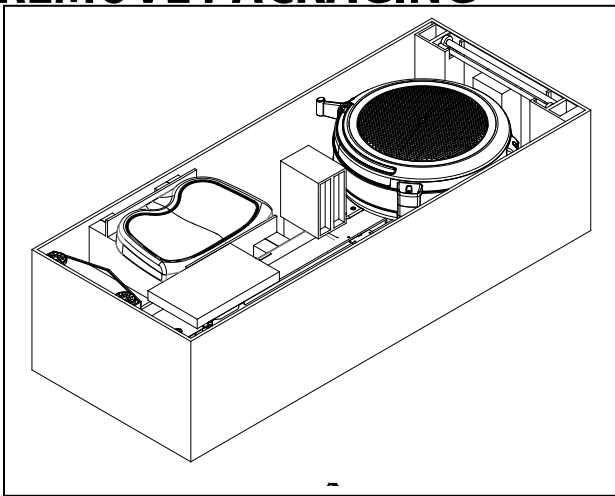





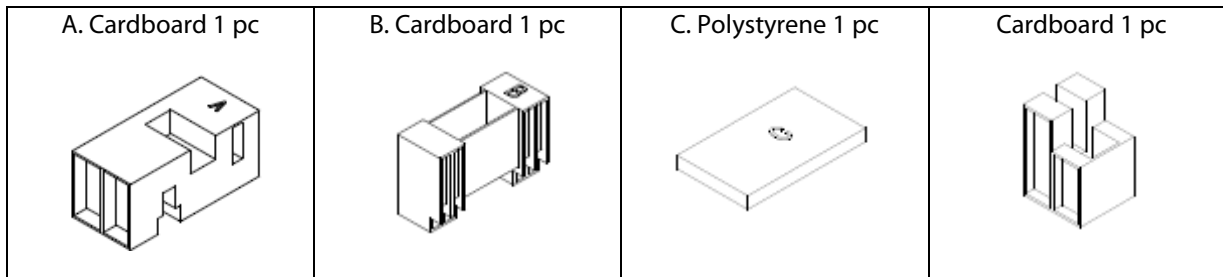

UNPACKING STEP 1

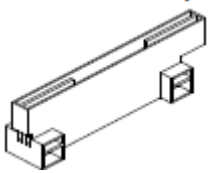
- #1. Main frame
- #2. Rail
- #160/161. Support Covers
- #7. Front support
- #4. Front Stabilizer
- #5. Footrests
- #19. Console
- #51. Seat
- #139. Pedal shaft, 16mm
- #140. Pedal shaft, 12mm
- #67. Rear end cap

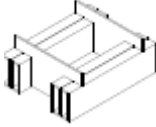
- Carefully remove all parts from the box. Be careful not to place the main frame on side, fan shrouds can dent easily if you put the weight of the whole frame on them.

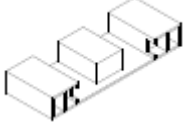
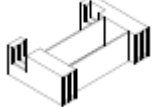

Cardboard 1 pc 	Cardboard 1 pc 	Cardboard 1 pc 	Cardboard 1 pc 
Cardboard 1 pc 	Cardboard 1 pc 	Polystyrene 1 pc 	

2 UNPACKING CONTINUED

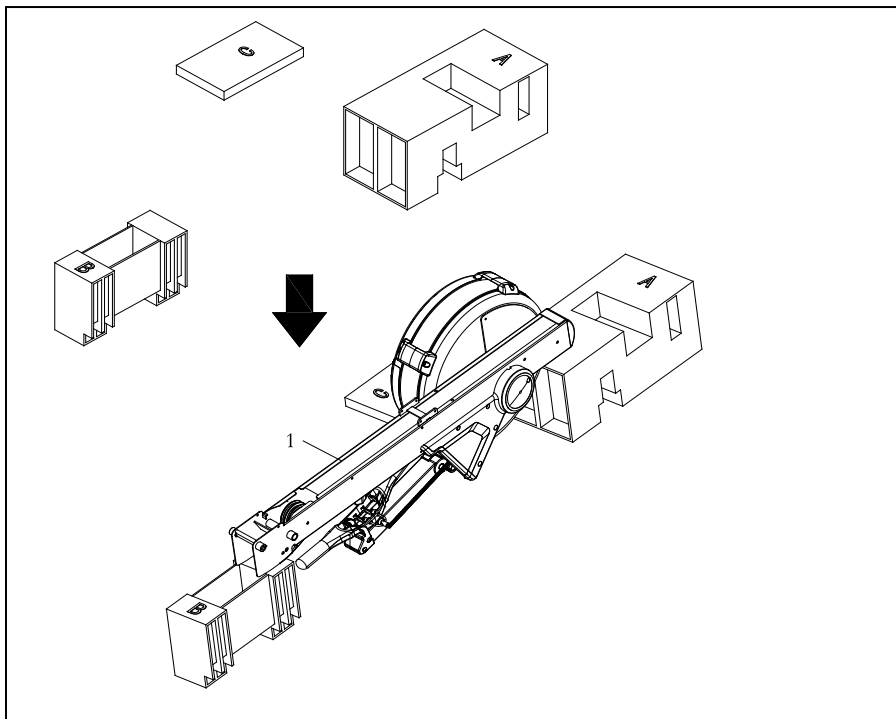

UNPACKING STEP 2

- #1. Main frame
- A. Cardboard
- B. Cardboard
- C. Polystyrene

1. Place the main frame (1) on the carton (A and B). Support the frame (1) with cartons (A and B), place polystyrene (C) between the two cartons for additional support of the frame.

Note: Placing the full weight of the frame on the fan shrouds may damage the shrouds.

3 FRAME

HARDWARE STEP 3

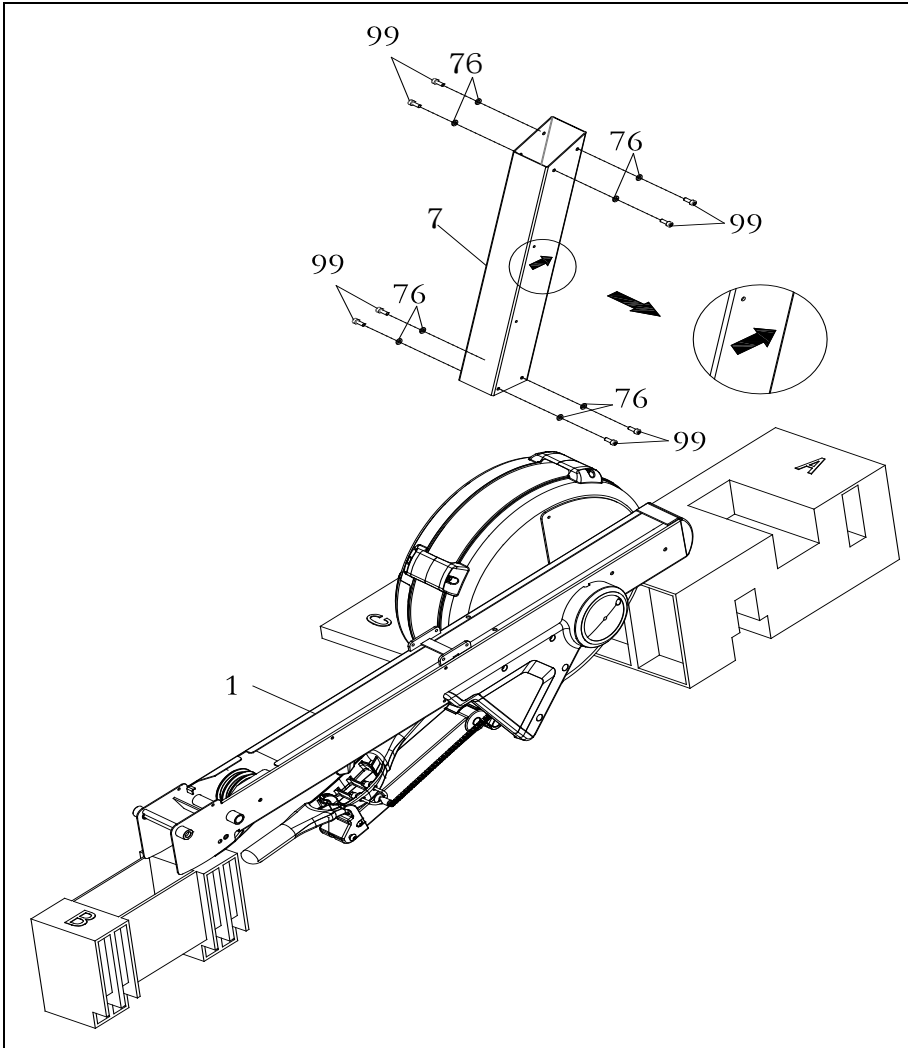

- #7. Front support
- #76. Washer M6
- #99. Allen screw (M6 x 16mm)

1. Attach the front frame (7), pay attention to the direction of the arrow, it must point outwards, see picture.
2. Attach the front frame (7) to the main frame (1) using 4x M8 flat washers (76) and 4x M6x16 Allen screws (99).
Note: Tighten all screws.

4 SUPPORT

HARDWARE STEP 4

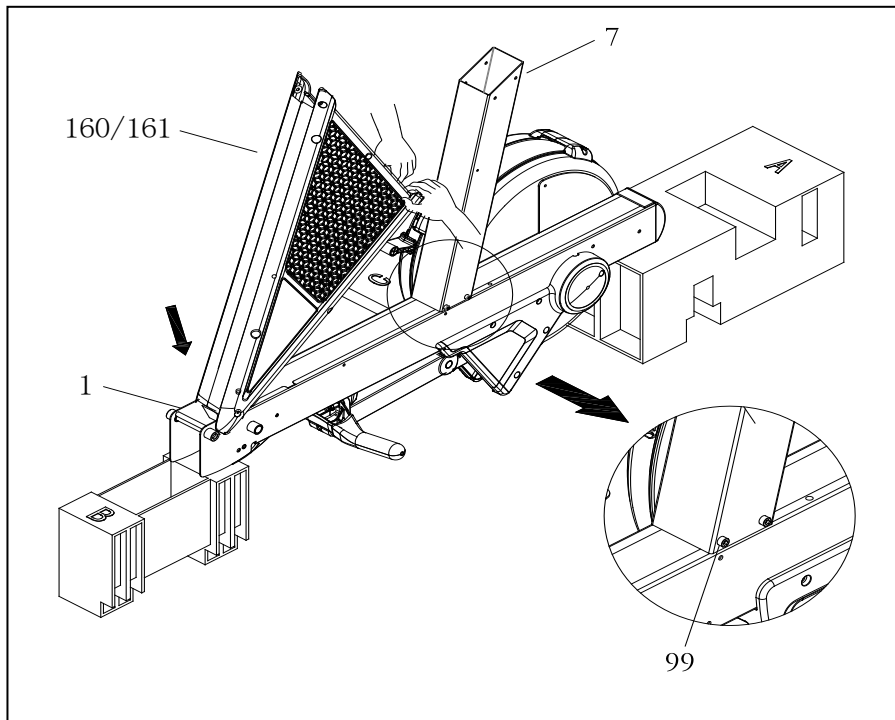

#160/161. Covers

#99. Allen screw (M6 x 16mm)

1. Align the pre-assembled triangular support cover (160/161) with the main frame as shown below (with the short edge of the triangular cover facing forwards).
2. Grasp the triangular cover with both hands and press it towards the main frame.
3. Gently pry open the triangular cover with both hands to allow the plastic to cover the screw (99) on the main frame.

5 SUPPORT COVERS

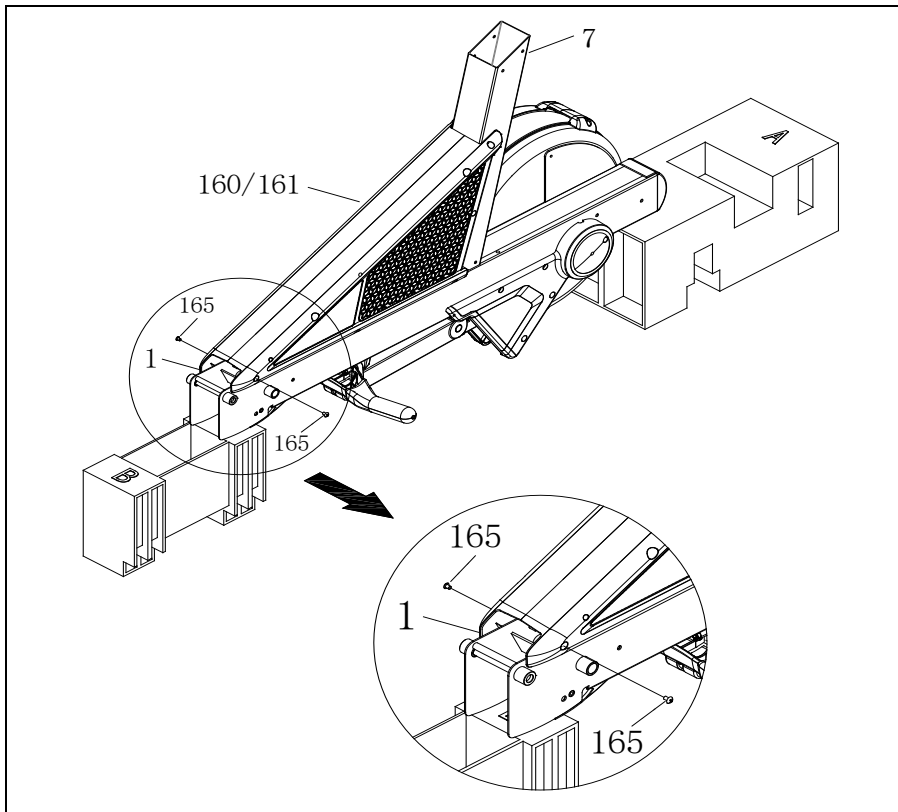

HARDWARE STEP 5

- #160/161. Covers
- #1. Main frame
- #7. Front support
- #165. Phillips screw (M6 x 12mm)

1. Fasten the covers (160 and 161) to the frame (1) and the front frame (7) using 10x Phillips screws (165), after tightening the 2 screws on main frame (1).
Note: Do not tighten all the screws yet.

6 COVERS CONTINUED

HARDWARE STEP 6

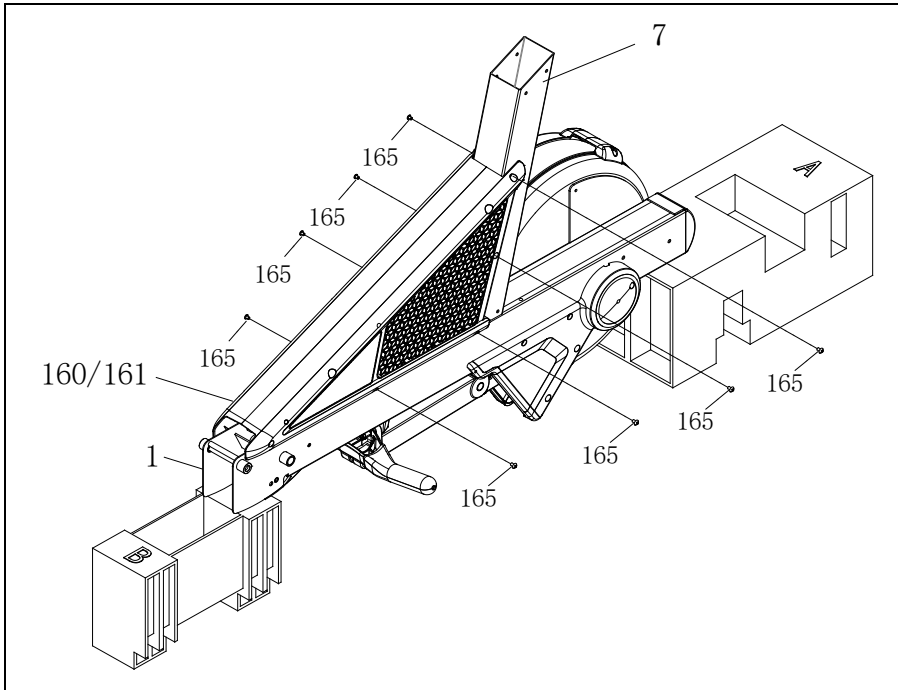

- #160/161. Covers
- #1. Main frame
- #7. Front support
- #165. Phillips screw (M6 x 12mm)

1. Secure the triangular support cover (160/161) to the main frame (1) and front support (7) using M6x12 cross-recess pan head screws (165) through the remaining holes.
Note: Then tighten all screws from steps 5 and 6.

7 FRONT STABILIZER

HARDWARE STEP 7

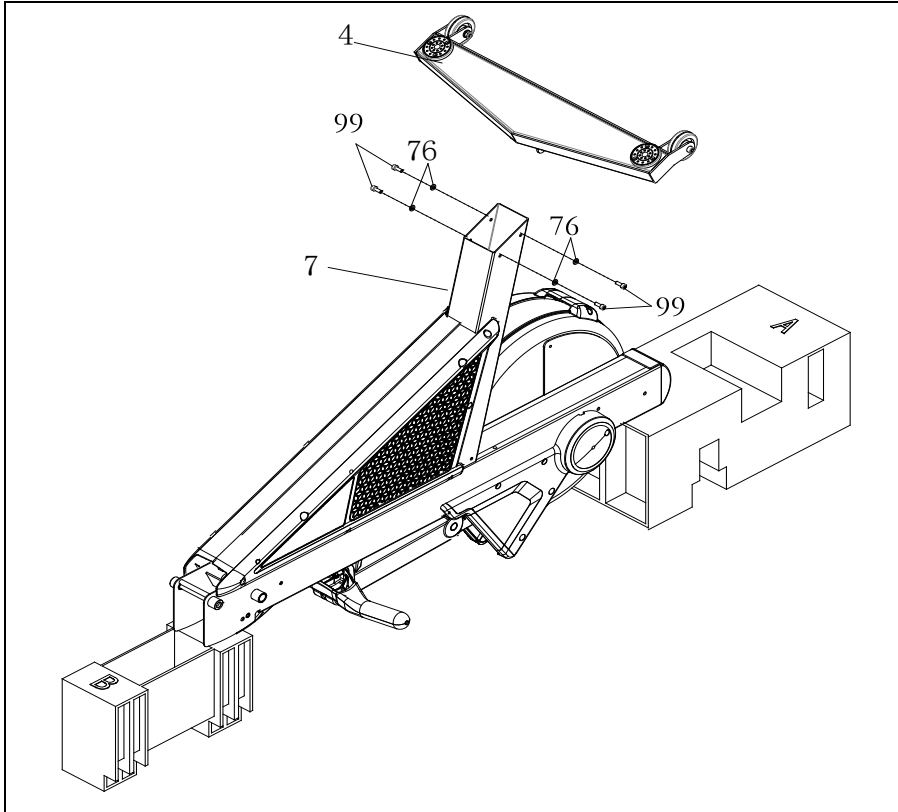

- #4. Front stabilizer
- #7. Front support
- #76. Washer M6
- #99. Allen screw (M6 x 16mm)

1. Attach the front stabilizer (4) to the front frame (7) using 4x washers (76) and 4x M6x16mm Allen screws (99).
Note: Tighten the screws.

8 FOOTRESTS

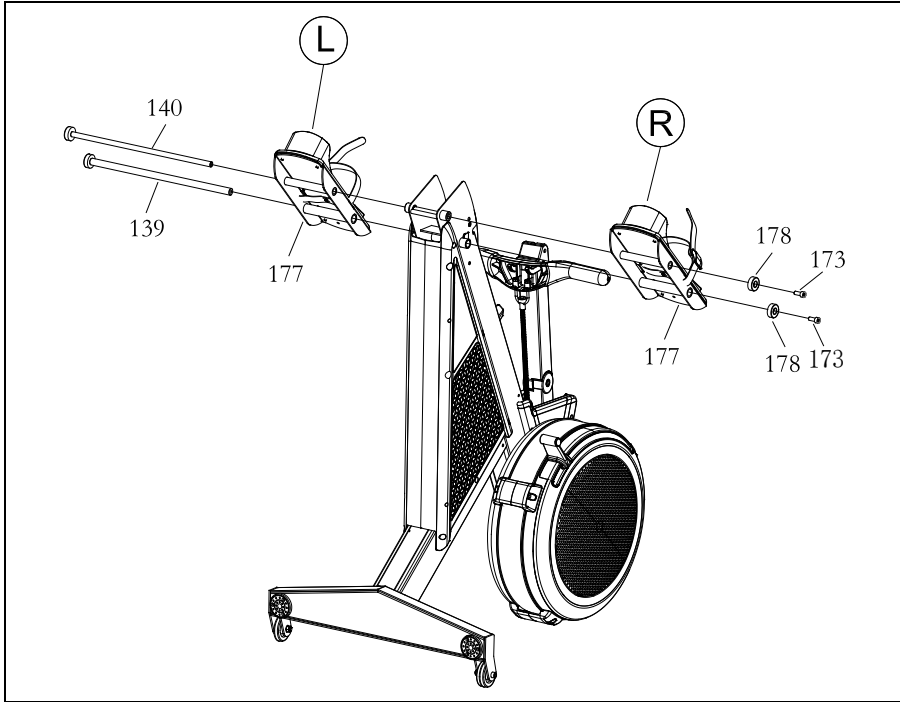

HARDWARE STEP 8

- #139. Pedal shaft, 16mm
- #140. Pedal shaft, 12mm
- #177. Footrest Support Plate
- #1. Main frame
- #99. Allen screw (M6 x 16mm)
- #173. Allen screw (M8 x 20mm)
- #178. Footrest stop block

1. As illustrated, turn the main frame upright. Pass the 16mm pedal shaft (139) and 12mm pedal shaft (140) through the footrest assembly (177) and main frame assembly (1). Secure the pedal assembly to the main frame assembly using Allen screw (M8 x 20mm) (173) and the footrest stop block (178).

9 SLIDE RAIL

HARDWARE STEP 9

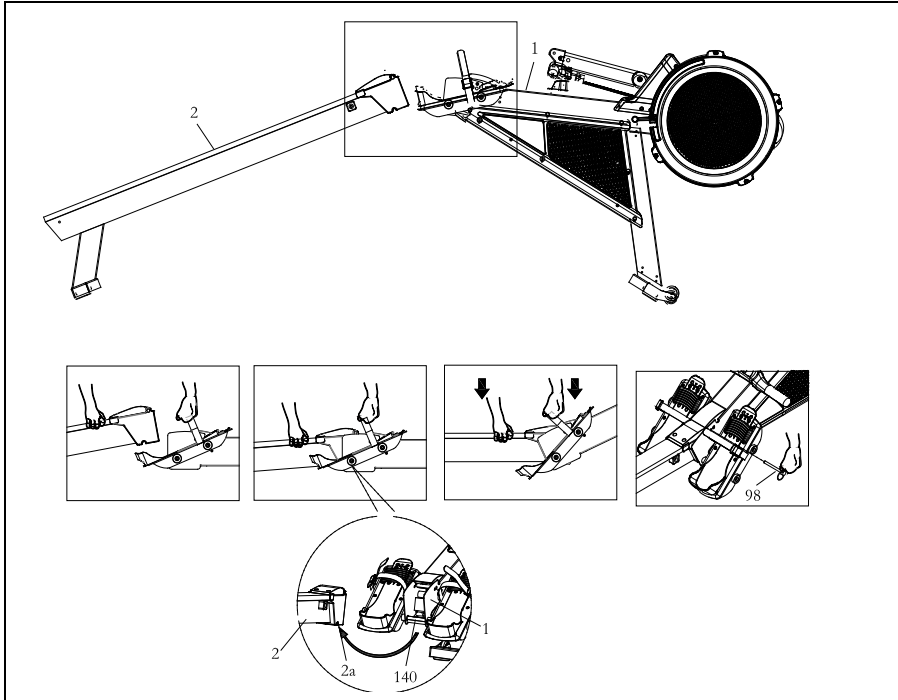

- #1. Main frame
- #47. Pedal strap
- #2. Rail frame
- #140. Pedal shaft, 12mm
- #98. Pull pin

1. Lift the frame (1) by grasping the pedal strap (47). Using the other hand, fit the rail (2) into the 12mm shaft (140) on the main frame (1). See picture.
2. Then insert the pin (98) into the main frame (1) and the rail (2).

10 CONSOLE ARM

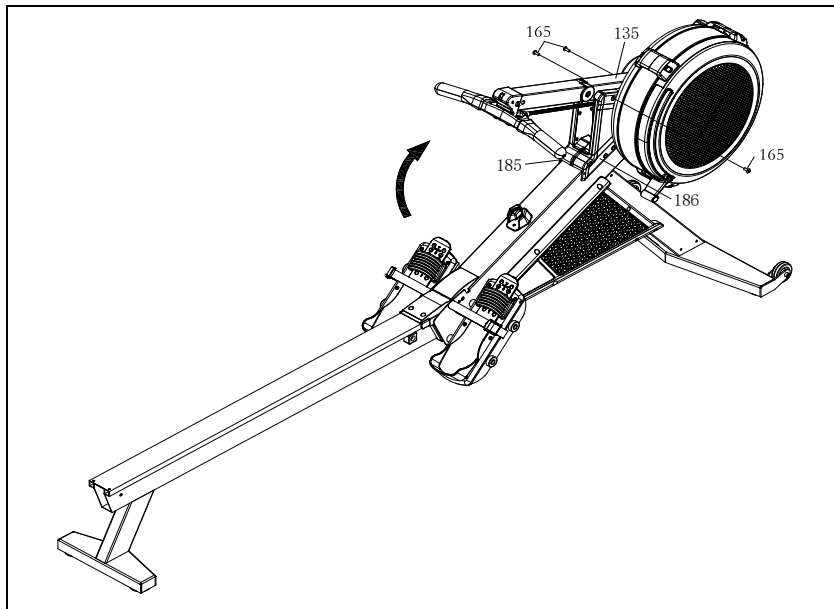

HARDWARE STEP 10

- #135. Lower console monitor arm
- #57. Left side cover
- #58. Right side cover
- #165. Phillips Pan Head Screw, (M6 x 12mm)

1. Attach the control panel bracket (135) to the covers (57 and 58) using 2 x M6x12 mm Phillips screws (165).
Note: Tighten all screws.

11 CONSOLE

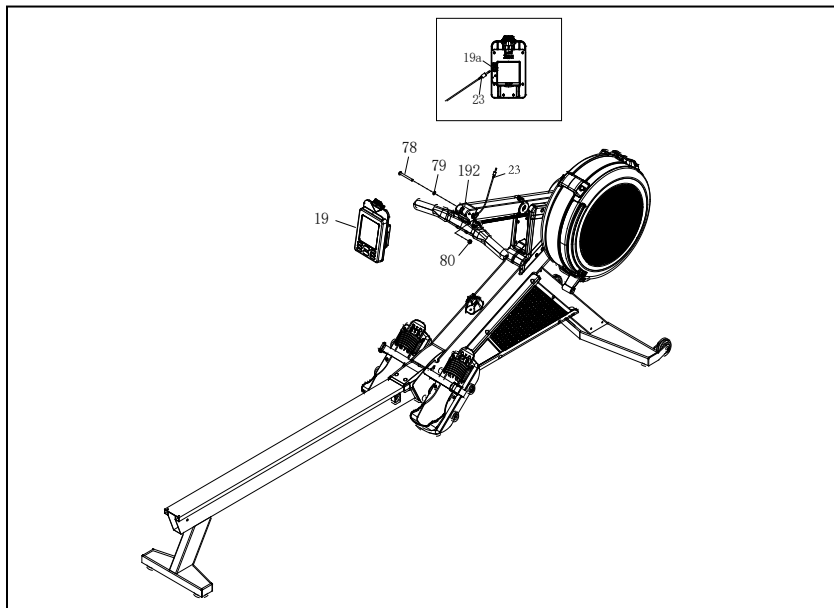

HARDWARE STEP 11

- #19. Console monitor
- #192. Console mounting bracket
- #78. Screw (M8 x 75mm)
- #79. Washer M8
- #80. Nut M8

1. Attach the console (19) to the bracket (192) using 1x M8x75mm screw (78), 1x M8 flat washer (79) and 1x M8 nut (80). Connect the sensor cable (23) to the console (19).

12 SADDLE

HARDWARE STEP 12

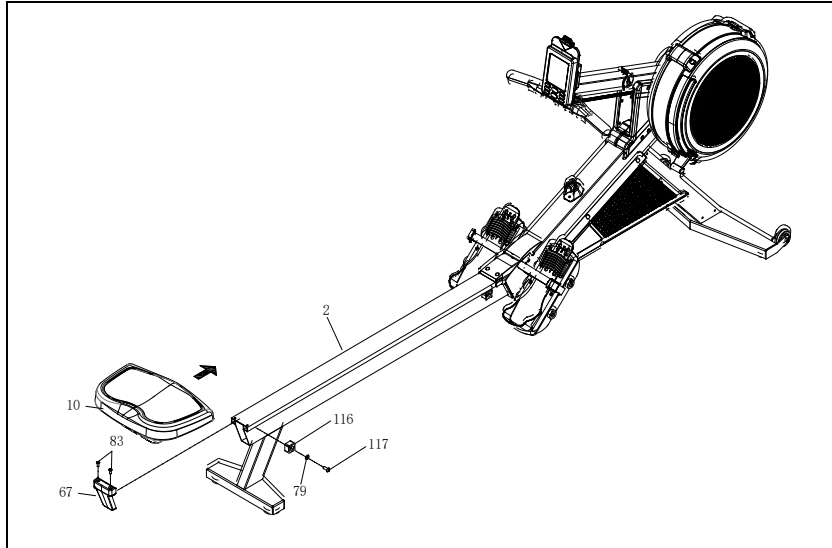

- #10. Seat Carriage
- #2. Rail frame
- #67. Rail end cap
- #83. Phillips screw (M6 x 16mm)
- #116. Stopper Bumper
- #79. Washer M8
- #117. Screw (M8 x 20mm)

1. Slide the saddle (10) onto the rail (2) and then attach the back cover (67) to the rail (2) with 2x M6x16mm screws (83).
 2. Fix the stopper (116) to the rail (2) with 1x M8 washer (79) and 1x screw (117).
- Note: Tighten all screws.

! FINAL CHECKS

Your rower is now fully assembled! Please make the following final checks before using it for the first time. Ensure all screws, bolts and nuts are tightened securely. Be sure to position the rower on a flat, level surface.

NOTE: Be sure to fit the parts in the same order as the diagrams shown. Make sure the cables are fully connected. Make sure the screw is fully tightened with the allen key.

RESISTANCE ADJUSTMENT

The resistance can be adjusted by turning the adjustment key, with 16 levels available from 1 to 16. Level 1 provides light resistance, while level 16 offers the strongest resistance. With a little experimentation, you will discover the resistance setting that delivers the best workout results for your needs.

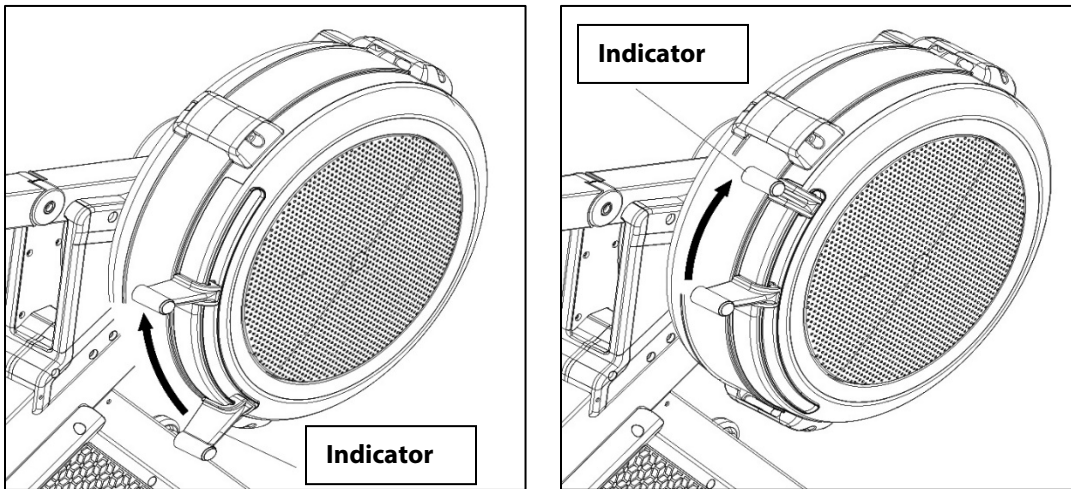

Resistance 11 – 16

Always set the indicator so that it is slightly above the desired value on the axis

Resistance 1 – 10

Always set the indicator so that it is slightly below the desired value on the axis

Note: always make sure that the desired value is displayed on the console.

If necessary, move the indicator so that the correct value is displayed on the console panel, not on the axis.

HANDLEBAR POSITION

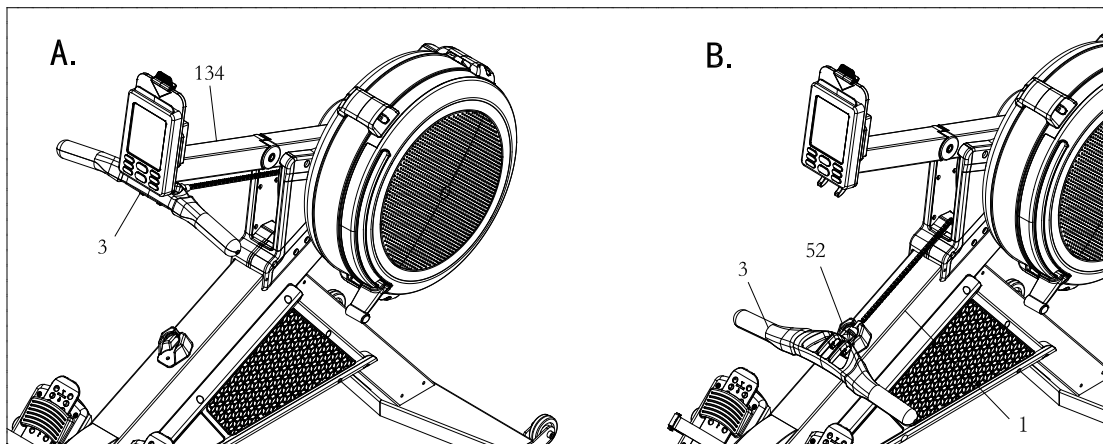

1. The handle (3) may be placed on the electronic display bracket (134), as shown in Figure A. Alternatively, the handle (3) may be positioned on the armrest fixing block (52), as illustrated in Figure B.

DEVICE HOLDER

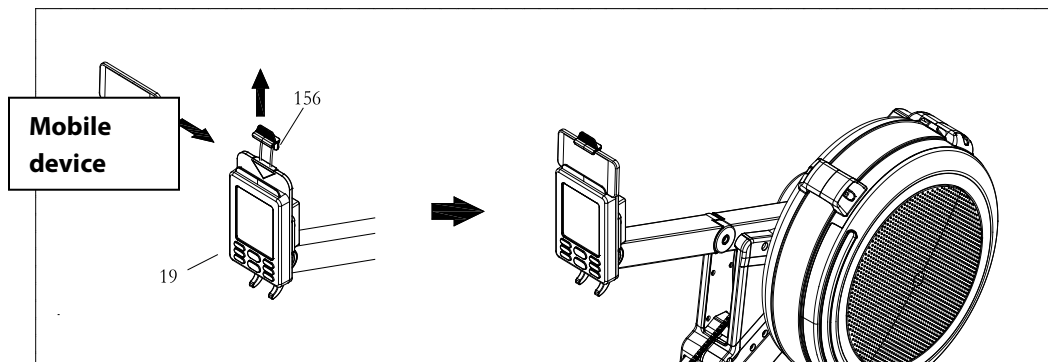

1. The device holder (156) can be moved up and down. Move the device holder (156), then slide the device into the gap between the device holder (156) and the electronic watch (19). Adjust the position of the device holder (156) to place the device in the correct position.

ADJUSTING THE CONSOLE ANGLE

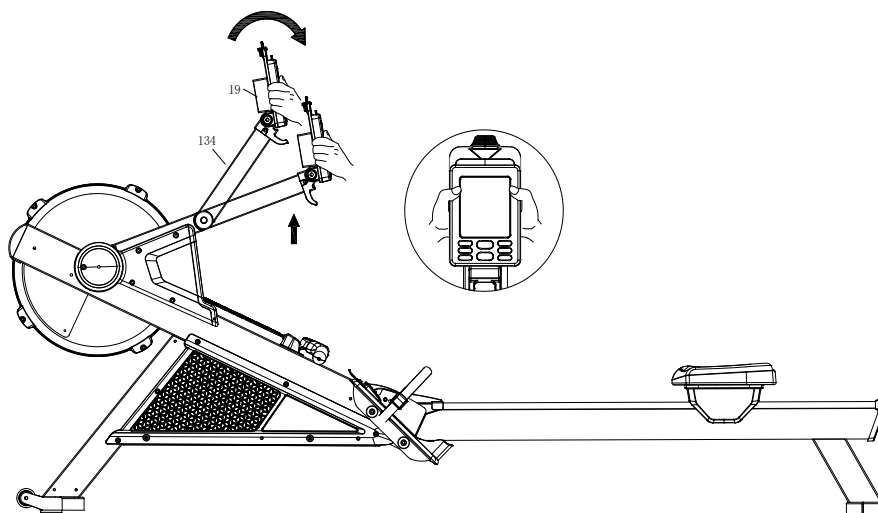

1. First grasp the console (19) with both hands, then lift upwards or press downwards on the console mount (134) to adjust the console monitor to a suitable position for training.

SECURING THE CONSOLE ARM

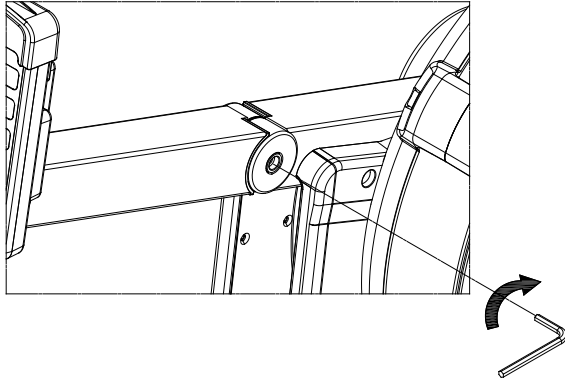

1. Over time, the console arm may feel slightly loose. Use a 5mm spanner to adjust the folding hinge to the appropriate tightness.

ADJUSTING THE FOOTRESTS

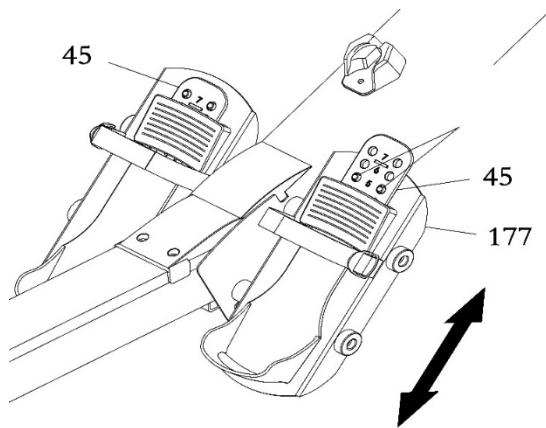

1. The position of the footrest adjustment plate (45) can be adjusted to alter the footrests, as illustrated. Pull the footrest adjustment plate (45) out from the two protrusions within the pedal bracket (177), then lower or raise the footrest adjustment plate (45) to the desired position. Press the adjustment hole at the desired position onto the two protrusions to lock the cover (45) securely in place.
2. Refer to the numbers on the footrest adjustment plate (45) to ensure the footrest adjustment plate (45) is adjusted to the same position on both sides.

LEVELLING THE ROWER

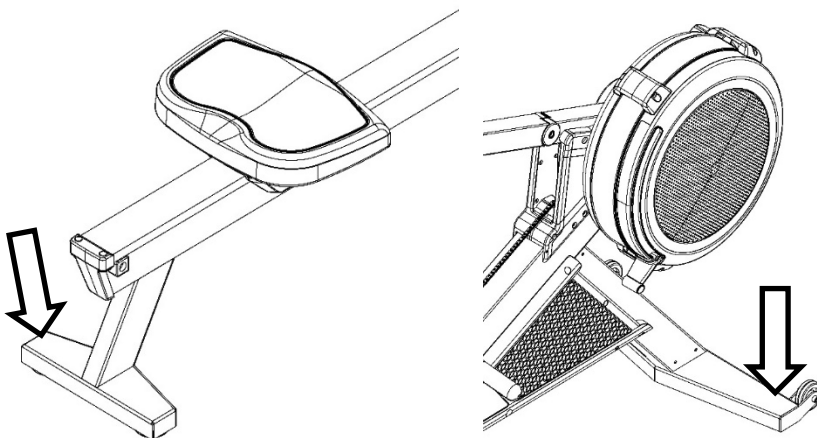

1. To help you level the rower on uneven surface, 2 height adjusters are included on the front and rear stabilizers. Simply turn it to adjust the height of the rower.

TRANSPORTING THE ROWER

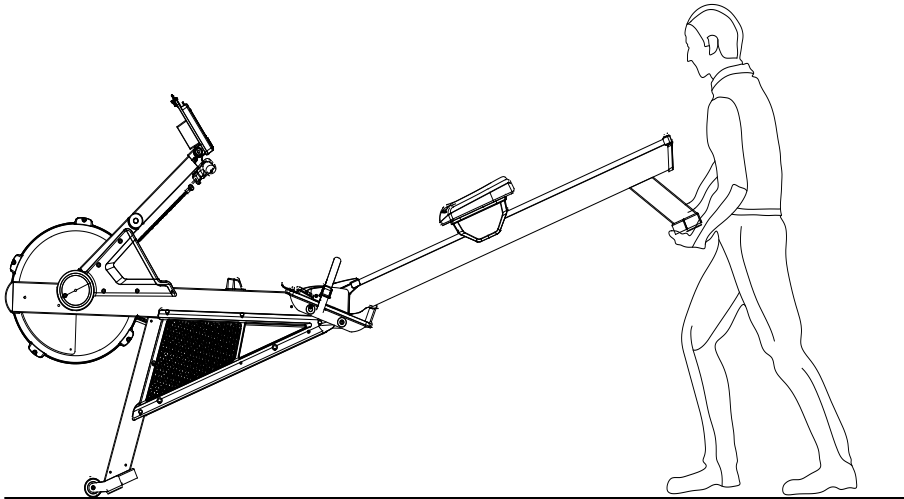

1. Move the rower on the transport wheels (66) on the front stabilizer (4).
2. Lift the rower by the rear stabilizer (2).
3. Never lift the trainer by the seat (51).

STORAGE OF THE ROWER

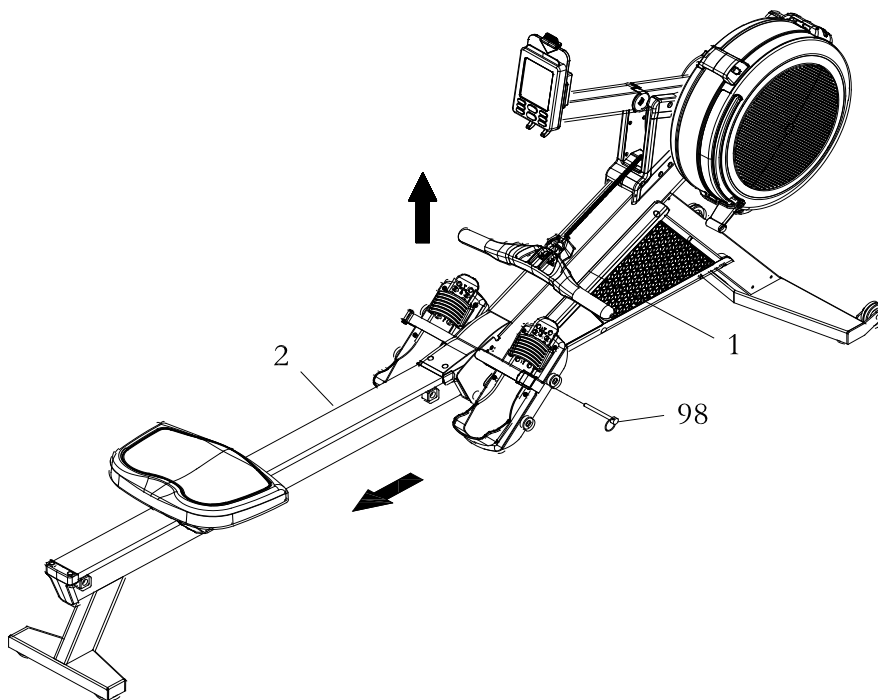

1. If necessary, you can disconnect the main frame (1) and the rails (2). Pull the pin (98) out of the main frame (1).
2. Once you have the frame and rail disconnected, insert the pin into the main frame.

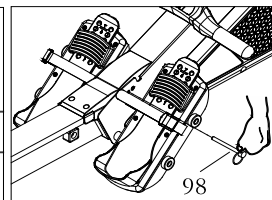
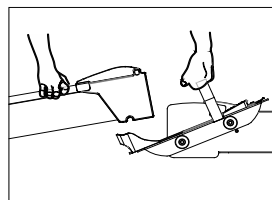
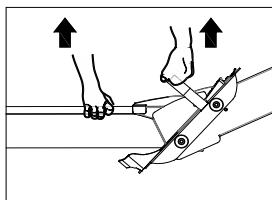
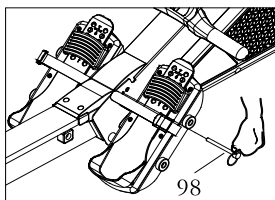

OPERATION OF YOUR ROWER

GETTING FAMILIAR WITH THE CONTROL PANEL

SR300 CONSOLE

The SOLESR300 Air/Magnetic Rowing Machine utilizes a combined air/magnetic fan system to create resistance for your workout. We recommend that you use this computer console to create variety your workout from session to session and note your progress toward your fitness goals. When used regularly in this way, the computer console can become an important source of motivation and interest which will help keep you on track.

FUNCTION BUTTONS

NOTE: Default exercising mode is Quick start program. Press any button to wake up the monitor. When the backlight is off, press any button to turn on the backlight.



UP: Press to increase the preset values. Press the button and hold it down, the presetting value will go faster, release the button to stop. In MEMORY mode, use to change between different workouts saved.

DOWN: Press to decrease the preset values. Press the button and hold it down, the presetting value will go faster, release the button to stop. In MEMORY mode, use to change between different workouts saved.

BACK: Press to go back to the previous step. When the program finishes, press the button to go back to the IDLE mode.

STOP: During any workout modes, pressing the first time will awake the backlight if the light is off. Pressing the second time will stop the workout. All the values will stop counting. Pressing the third time will enter the SUMMARY to view your workout result. Pressing the fourth time to go back to the IDLE mode.

During any workout modes, pressing the STOP button will pause the counting of all the value. Monitor show the PAUSE icon. The heart rate will also be shown if the user is wearing the compatible hear rate belt. The monitor will start counting the value when the user start exercising.

During program modes, not including Quick Start mode you must press stop in order to save your workout into memory.

Hold STOP button and everything well reset and return you to IDLE mode

ENTER: When selecting the programs and presetting target values, press the button to confirm or go into next value setting.

TARGET: In the IDLE mode, press the button to enter the Target Countdown Programs. Keeping pressing the button to cycle through the programs in the following sequence: DISTANCE -> CALORIE -> TIME. In the TARGET program, you will be asked to set the target value. The flashing number indicates the value you need to set as the target.

INTERVALS: In the IDLE mode, press the button to enter the Interval Programs. Keeping pressing the button to cycle through the programs in the following sequence: DISTANCE -> CALORIE -> TIME. In the Interval Programs, you will be asked to set the Workout value and the resting value. The flashing number indicates the value you are setting.

SELECT: In any program, press the button to change the display values in the window. Press the first time to view the different values. Press the second time to alter the values every 5 seconds. You will hear two beep sounds when you press the button for the second time.

POWER ON: When sensor is connected, start rowing and it will enter Quick Start. Press any buttons to turn on computer and it will enter IDLE mode.
POWER OFF: In IDLE mode, automatically shuts off after 1 minute of inactivity. In all other programs, automatically shuts off after 2 minutes of inactivity.

HOW TO INSTALL AND REPLACE BATTERIES

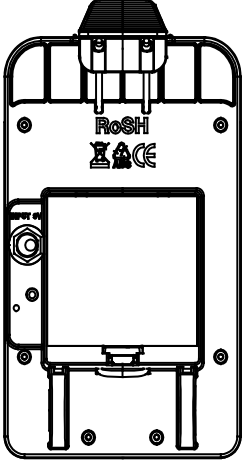

Console operates using 2 D-type batteries. The battery compartment is on the back of the console.

NOTE:

1. Do not mix a new battery with an old battery.
2. Use only one type of battery. Do not mix alkaline with other battery types.
3. Rechargeable batteries are not recommended.
4. Dispose of batteries in accordance with all applicable local laws.
5. Do not dispose of batteries in fire.

Console Display

S/M (STROKE RATE): Displays the current stroke per minute during exercise. Display range: 0-99.

STROKES & METER/30MIN: STROKES displays the total number of strokes during exercise. Display range 0 - 99999. METER/30MIN displays the estimate distance based on the current S/M. Display range 0 - 99999.

TIME: Display range: 00:00 - 99:59 (Minutes: Seconds). The numbers go back to 00:00 if reaching the max time. The workout time is accumulated when under any workout mode. Except for Time Countdown Program.

TIME/500M: Displays the estimate time to reach 500 meters. Display range 00:00 - 99:59.

AVE /500M & M: Displays the estimate average time to reach 500 meters. Display range 00:00 - 99:59. M displays the total distance accumulated in the exercise. Display range 0 - 99999. In the Distance Countdown Program, the default setting is 500 meters. Display range 100 - 99900m. In the Distance Interval Program, the default setting is 500 meters. Display range 100 - 50000m. When setting the distance, the number changes by 100 every time the button is pressed.

CAL/HR & WATT: CAL/HR displays the estimate calories accumulated in an hour. Display range 0 - 9999. WATT displays the current watt during the exercise. Display range 0 - 9999.

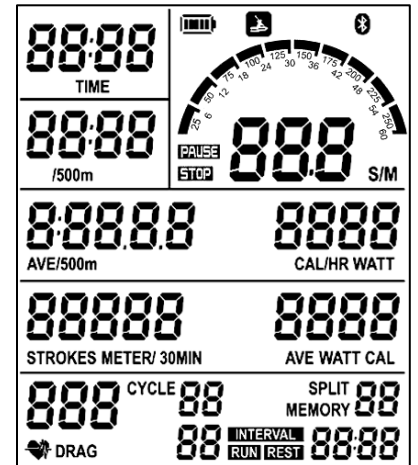

AVE WATT & CAL: AVE WATT displays the average watt during the exercise. Display range 0 - 9999. CAL displays the total calories accumulated in the exercise. Display range 0 - 9999. In the Calorie Countdown Program, the default setting is 20 cal. Display range 10 - 9999. In the Calorie Interval Program, the default setting is 20 cal. Display range 10 - 9990. Each time the up or down button are pressed, the setting changes by 1 cal.

♥ **PULSE & DRAG:** Displays the heart rate from 40 to 220 beats per minute during exercise. To use this function, the user must wear Heart Rate Chest Strap with a 5.3K Hz frequency. Display Drag Factor value is a number for reference of the rowing cadence and resistance you feel.

INTERVAL: Displays only in INTERVAL programs. It is accumulated up to let you know which cycle of interval you are on.

RUN & REST: RUN and REST will only appear in the Interval Programs. In the Time Interval Program, RUN displays the remaining time for workout. The display range is 0:20 - 99:00. In the Distance Interval Program and Calorie Interval Program, RUN displays the accumulated time for workout. Display ranges from 0:20 - 99:59. REST displays the remaining time for break in the interval programs. The display range is 00:01 - 99:59. In the settings, each press of the UP or DOWN buttons changes the number by 1 unit.

SPLIT & MEMORY & LEVEL: MEMORY displays the workout history. Use SELECT button to enter the program. SPLIT doesn't display during the exercise, but only in the summary and memory program. SPLIT XX indicates which segment of movement. Display range 0 -99.

PROGRAMS

The console monitor has 8 programs. Press **SELECT** to change workout programs according to the following sequence.

Quick Start Program > Distance Countdown > Time Countdown > Calories Countdown > Time Interval > Distance Interval > Calories Interval > Memory Mode

Press **"INTERVAL"** button to enter the Interval Programs. Press multiple times to cycle through the Distance, Calories, Time Interval Programs.

Press **"Target"** button to enter the Countdown Programs. Press multiple times to cycle through the Distance, Calories, Time Countdown Programs.

For Quick Start and all programs, press **"DISPLAY"** button to choose the data displayed in the same display window. Or let it scan between every 5 seconds.

Press **"STOP"** button once to stop counting, CALORIES and WATT value with display 0. Press **"STOP"** button again and computer will show your workout summary. Press **"STOP"** button again in workout summary to save workout into memory mode and enter back into IDLE mode.

Note: The QUICK START workout summary will not be saved into memory mode.

1. QUICK START PROGRAM

To Quick Start the program, start rowing. All function values for the console will count up. You can start Quick Start in either POWER OFF or IDLE mode.

Quick Start mode will have a summary of the workout when you hit STOP, but it will not be saved into MEMORY mode.

2. TIME COUNTDOWN PROGRAM

During the workout, the "TIME" program will count down from preset value.

- Workout value setting range: 01:00 - 99:00. The default setting is 20:00.
- The program will start once the user begins pulling the handlebar. When the program is finished, the monitor will show your workout summary. Press "STOP" button to save into memory and back to IDLE mode

3. DISTANCE COUNTDOWN PROGRAM

During the workout, the "DISTANCE" program will count down from preset value.

- Workout value setting range: 500 - 9990m. The default setting is 500m.
- The program will start once the user begins pulling the handlebar. When the program is finished, the monitor will show your workout summary. Press "STOP" button to save into memory and back to IDLE mode

4. CALORIES COUNTDOWN PROGRAM

During the workout, the "CALORIES" program will count down from preset value.

- Workout value setting range: 10 - 9990 cal. The default setting is 20 cal.
- The program will start once the user begins pulling the handlebar. When the program is finished, the monitor will show your workout summary. Press "STOP" button to save into memory and back to IDLE mode.

5. TIME INTERVAL PROGRAM

When "TIME INTERVAL" program is selected, you will see TIME flashing.

- You will set the desired workout time of each interval first. Once finish setting press "ENTER" button to set the REST TIME of each interval. Press "ENTER" button again to set the target cycles.
- When finishing all the settings, press "ENTER" to start the exercise.
- Workout time value setting range: 00:20 - 99:00. The default setting is 30 seconds.
- Rest time value setting range: 00:10 - 30:00. The default setting is 30 seconds.
- Cycle value setting range: 1 - 99. The default setting is 1.

6. DISTANCE INTERVAL PROGRAM

When "DISTANCE INTERVAL" program is selected, you will see M flashing.

- You will set the desired workout meters of each interval first. Once finish setting press "ENTER" button to set the REST TIME of each interval. Press "ENTER" button again to set the target cycles.
- When finishing all the settings, press "ENTER" to start the exercise.
- Workout time value setting range: 100~50000. The default setting is 500m.
- Rest time value setting range: 00:10~30:00. The default setting is 30 seconds.
- Cycle value setting range: 1 - 99. The default setting is 1.

7. CALORIES INTERVAL PROGRAM

When "CALORIES INTERVAL" program is selected, you will see CAL flashing.

- You will set the desired workout calories of each interval first. Once finish setting press "ENTER" button to set the REST TIME of each interval. Press "ENTER" again to set the target cycles.
- When finishing all the settings, press "ENTER" to start the exercise.
- Workout time value setting range: 10 - 9990. The default setting is 20.
- Rest time value setting range: 00:10~30:00. The default setting is 30.
- Cycle value setting range: 1 - 99. The default setting is 1.

8. MEMORY MODE

Press the **"SELECT"** button in the IDLE mode to enter the **MEMORY MODE**. Press **"ENTER"** to confirm.

- Press **"UP"** and **"DOWN"** button to view the different summary reports in the history. The maximum number is 99.
- Only program modes workout summary will be saved to **MEMORY MODE**. Quick Start will not be saved to **MEMORY MODE**
- The computer memory can save at most 99 sets of data or 99 splits of data. Computer will only save up to 99 workouts. (Example: When you row 1000M countdown, you will save 3 sets of data. 1 total average and 2 500M split data)
- When you try to save a workout summary and the computer does not have enough memory it will automatically erase the oldest workout(s) in order to save your newest workout into memory.
- The lower the number under **MEMORY** the newer the workout is.
- You can press **"SELECT"** button to switch the display of the value.
- When **SPLIT** displays **"00"** it means it is the total workout average with no splits.

Below is how the computer decides to split the data into:

Time Countdown Mode

Rule	Splits by
10 hour > TIME > 5 hour	30min
5 hour >= TIME > 200min	15min
200min >= TIME > 100min	10min
100min >= TIME > 60min	5min
60min >= TIME > 20min	3min
20min >= TIME > 5min	1min
5min >= TIME > 1min	30sec
1min >= TIME	20sec

Calories Countdown Mode

Rule	Splits by
5000 >= Calories > 4000	250cal
4000 >= Calories > 3000	200cal
3000 >= Calories > 2000	150cal
2000 >= Calories > 1000	100cal
1000 >= Calories > 500	50cal
500 >= Calories > 100	20cal
100 >= Calories	10cal

Interval Program Modes

Rule	Splits
1 Cycle = 1 Split	Up to 35

Distance Countdown Mode

Rule	Splits
500>= Distance >250	20km
250>= Distance >100	10m
100>= Distance >50	5m
50>= Distance >20	2m
20>= Distance	1m

NOTE: IF YOU SET A WORKOUT VALUE THAT IS NOT A MULTIPLE OF THE SPLIT DATA, THE LAST SPLIT WILL NOT DISPLAY WHEN YOU VIEW YOUR SPLITS, BUT WILL BE ADDED TO THE TOTAL WORKOUT SPLIT "00"

Example: If you set 1200M and finish the workout, Split "00" will show the total average of 1200M, but when you view the splits, you will only see 2 500M splits and will not have a 3rd split of 200M. It will be the same if you stop midway of the workout.

BLUETOOTH CONNECTION

Please make sure the console is activated in order to proceed Bluetooth connection with your smart-phone or tablet devices.

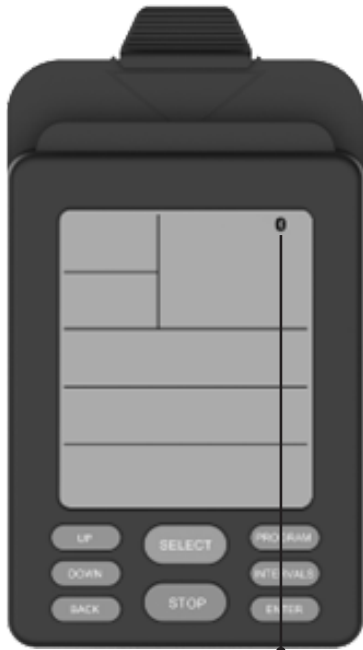

The icon will be displayed at the top right of console screen when it's connected to an app.

AVAILABLE APPS



SOLE +



Kinomap



Zwift

... and more!

FTMS PROTOCOL



Explore the SOLE+ App



* Go to the Settings menu on your device to allow the apps to access the Bluetooth connection.

INDOOR ROWER TROUBLESHOOTING

Problem	Cause	Correction
Monitor does not display	Batteries not installed	Insert batteries
No speed or distance displays on the monitor	Connected wire doesn't connect with extension wire of computer	Securely plug connected wire into extension wire of computer
	Connected wire is damaged	Replace connected wire
	Computer not working properly	Replace computer
Grinding	Idler pulley defective	Replace idler pulley
	Fan wheel defective	Replace fan wheel
Squealing	Belt slipping	Adjust belt
	Crank bearing defective	Replace crank bearing
	Idler wheel bearing defective	Replace idler wheel bearing
	Fan wheel bearing defective	Replace fan wheel bearing

STORAGE

1. To store the **rower**, simply keep it in a clean dry place.
2. To move the **rower**, lift the handle at the back of the **rower** and use the **transport wheels (66)** on the **front stabilizer (4)**. Never lift the trainer by the **seat (51)**.
3. To avoid damage to the electronics, remove the batteries from the **monitor (19)** before storing the **rower** for one year or more.

MAINTENANCE

The safety and integrity designed into the **rower** can only be maintained when the **rower** is regularly examined for damage and wear. Special attention should be given to the following:

1. Pull on the **handlebar (3)** and verify that the Magnetic System provide tension.
2. Clean the gaps in the **console mounting bracket (179)** and **seat (51)** with an absorbent cloth.
3. It is the sole responsibility of the user/owner to ensure that regular maintenance is performed.
4. Worn or damaged components must be replaced immediately or the **rower** should be removed from service until repair is made.
5. Only supplied components should be used to maintain/repair the **rower**.
6. Keep your **rower** clean by wiping it off with an absorbent cloth after training.

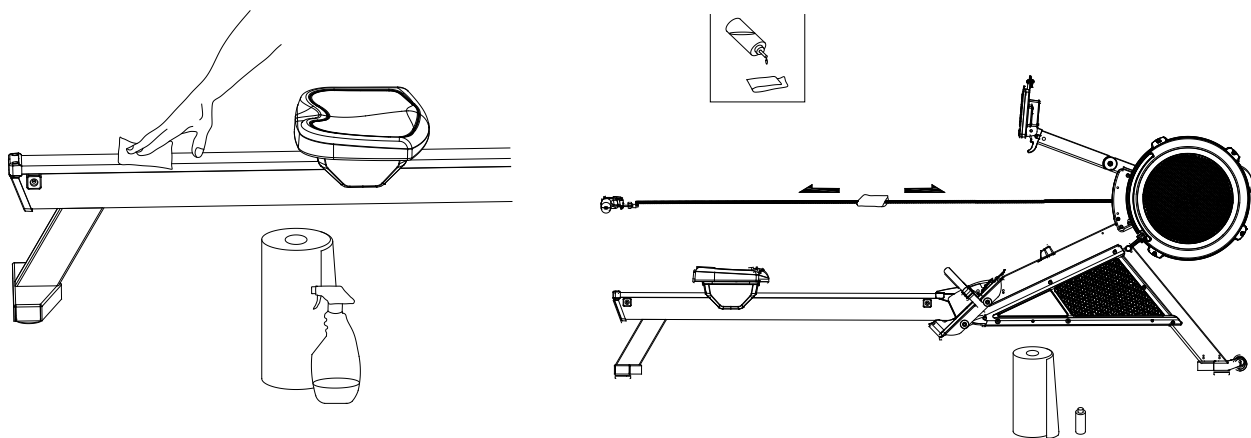

Every 50 hours of use

Lubricate the chain with a teaspoon of purified mineral oil, 3-IN-ONE oil, or 20W motoroil. Apply oil to a paper towel, and rub the paper towel along the entire length of the chain. Wipe off the excess. Repeat if needed. Do not clean the chain with any kind of cleaner or solvent, e.g. WD-40.

Every 25 hours of use

1. Inspect the chain for stiff links. If thorough lubrication does not help, the chain should be replaced.
2. Inspect chain-handle connection for wear. If the hole has become elongated, or the U-bolt is worn half way through, replace the entire connection.
3. Tighten the shock cord if the handle does not return all the way to the fan enclosure.
4. Check screws for tightness, including those used for assembly.
5. Loosen or tighten the nuts on the Performance Monitor arm joints as necessary.
6. Check for dust inside flywheel with a flashlight. Vacuum if needed.

HOW TO CLEAN THE FLYWHEEL

Dust and lint may collect inside the flywheel and on the stainless-steel mesh. This will restrict airflow and lower the resistance of the fan. The flywheel and mesh can be cleaned as directed in the illustrations below.

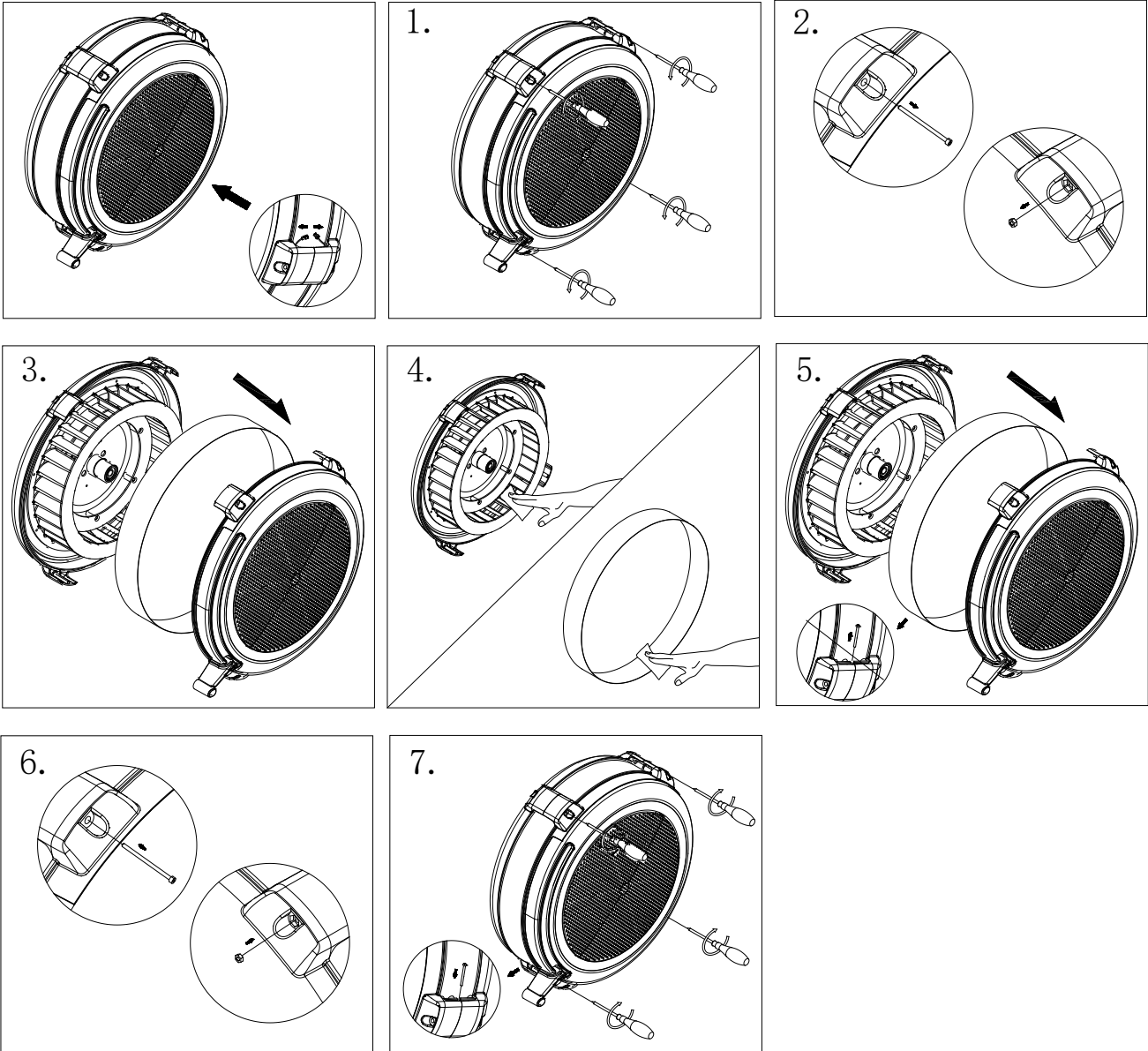

TRAINING GUIDELINES

EXERCISE

Exercise is one of the most important factors in the overall health of an individual. Listed among its benefits are:

- Increased capacity for physical work (strength endurance)
- Increased cardiovascular (heart and arteries/veins) and respiratory efficiency
- Decreased risk of coronary heart disease
- Changes in body metabolism, e.g. losing weight
- Delaying the physiological effects of age
- Physiological effects, e.g. reduction in stress, increase in self-confidence, etc.

BASIC COMPONENTS OF PHYSICAL FITNESS

There are four all-encompassing components of physical fitness and we need to briefly define each and clarify its role.

Strength is the capacity of a muscle to exert a force against resistance. Strength contributes to power and speed and is of great importance to a majority of sports people.

Muscular Endurance is the capacity to exert a force repeatedly over a period of time, e.g. it is the capacity of your legs to carry you 10 Km without stopping.

Flexibility is the range of motion of a joint. Improving flexibility involves the stretching of muscles and tendons to maintain or increase suppleness, and provides increased resistance to muscle injury or soreness.

Cardio-respiratory endurance is the most essential component of physical fitness. It is the efficient functioning of the heart and lungs.

AEROBIC FITNESS

The largest amount of oxygen that you can use per minute during exercise is called your maximum oxygen uptake (MVo₂). This is often referred to as your aerobic capacity.

The effort that you can exert over a prolonged period of time is limited by your ability to deliver oxygen to the working muscles. Regular vigorous exercise produces a training effect that can increase your aerobic capacity by as much as 20 to 30%. An increased MVO₂ indicates an increased ability of the heart to pump blood, of the lungs to ventilate oxygen and of the muscles to take up oxygen.

Anaerobic Training

This means "without oxygen" and is the output of energy when the oxygen supply is insufficient to meet the body's long-term energy demands. (For example, 100-meter sprint).

The Training Threshold

This is the minimum level of exercise which is required to produce significant improvements in any physical fitness parameter.

Progression

As you become fitter, a higher intensity of exercise is required to create an overload and therefore provide continued improvement.

Overload

This is where you exercise at a level above that which can be carried out comfortably. The intensity, duration and frequency of exercise should be above the training threshold and should be gradually increased as the body adapts

to the increasing demands. As your fitness level improves, so the training threshold should be raised. Working through your program and gradually increasing the overload factor is important.

Specificity

Different forms of exercise produce different results. The type of exercise that is carried out is specific both to the muscle groups being used and to the energy source involved.

There is little transfer of the effects of exercise, i.e. from strength training to cardiovascular fitness. That is why it is important to have an exercise program tailored to your specific needs.

Reversibility

If you stop exercising or do not do your program often enough, you will lose the benefits you have gained. Regular workouts are the key to success.

WARM-UP

Every exercise program should start with a warm-up where the body is prepared for the effort to come. It should be gentle and preferably use the muscles to be involved later.

Stretching should be included in both your warm-up and cool-down, and should be performed after 3-5 minutes of low-intensity aerobic activity or callisthenic type exercise.

Warm Down or Cool Down

This involves a gradual decrease in the intensity of the exercise session. Following exercise, a large supply of blood remains in the working muscles. If it is not returned promptly to the central circulation, pooling of blood may occur in the muscles.

Heart Rate

As you exercise, the rate at which your heart beats also increases. This is often used as a measure of the required intensity of exercise. You need to exercise hard enough to condition your circulatory system and increase your pulse rate, but not enough to strain your heart.

Your initial level of fitness is important in developing an exercise program for you. If you are starting off, you can get a good training effect with a heart rate of 110-120 beats per minute (BPM). If you are fitter, you will need a higher threshold of stimulation.

To begin with, you should exercise at a level that elevates your heart rate to about 65 to 70% of your maximum. If you find this is too easy, you may want to increase it, but it is better to lean on the conservative side.

As a rule of thumb, the maximum heart rate is 220 minus your age. As you increase in age, your heart, like other muscles, loses some of its efficiency. Some of its natural loss is won back as fitness improves.

The following table is a guide to those who are "starting fitness".

Age	25	30	35	40	45	50	55	60	65
Target Heart Rate									
10 Second Count	23	22	22	21	20	19	19	18	18
Beats per Minute	138	132	132	126	120	114	114	108	108

Pulse Count

The pulse count (on your wrist or carotid artery in the neck, taken with two index fingers) is done for ten seconds, taken a few seconds after you stop exercising. This is for two reasons: (a) 10 seconds is long enough for accuracy, and (b) the pulse count is to approximate your BPM rate at the time you are exercising. Since heart rate slows as you recover, a longer count isn't as accurate.

The target is not a magic number, but a general guide. If you have above average fitness, you may work quite comfortably a little above that suggested for your age group.

The following table is a guide to those who are keeping fit. Here we are working at about 80% of the maximum.

Age	25	30	35	40	45	50	55	60	65
Target Heart Rate									
10 Second Count	26	26	25	24	23	22	22	21	20
Beats per Minute	156	156	150	144	138	132	132	126	120

Don't push yourself too hard to reach the figures on this table. It can be very uncomfortable if you overdo it. Let it happen naturally as you work through your program. Remember, the target is a guide, not a rule, a little above or below is just fine.

Two final comments:(1) don't be concerned with day-to-day variations in your pulse rate, being under pressure or not enough sleep can affect it;(2) your pulse rate is a guide, don't become a slave to it.

ENDURANCE CIRCUIT TRAINING

Cardiovascular endurance, muscle, strength, flexibility and coordination are all necessary for maximum fitness. The principle behind circuit training is to give a person all the essentials at one time by going through your exercise program moving as fast as possible between each exercise. This increases the heart rate and sustains it, which improves the fitness level. Do not introduce this circuit training effect until you have reached an advanced program stage.

Body Building

Is often used synonymously with strength training. The fundamental principle here is OVERLOAD. Here, the muscle works against greater loads than usual. This can be done by increasing the load you are working against.

Patronization

This is the term used to vary your exercise program for both physiological and psychological benefits. In your overall program, you should vary the workload, frequency and intensity. The body responds better to variety and so do you. In addition, when you feel yourself getting "stale", bring in periods of lighter exercise to allow the body to recuperate and restore its reserves. You will enjoy your program more and feel better about it.

Muscle Soreness

For the first week or so, this may be the only indication you have that you are on an exercise program. This, of course, does depend on your overall fitness level. A confirmation that you are on the correct program is a very slight soreness in most major muscle groups. This is quite normal and will disappear in a matter of days.

If you experience major discomfort, you may be on a program that is too advanced or you have increased your program too rapidly.

If you experience PAIN during or after exercise, your body is telling you something.

Stop exercising and consult your doctor.

WHAT TO WEAR

Wear clothing that will not restrict your movement in any way while exercising. Clothes should be light enough to allow the body to cool. Excessive clothing that causes you to perspire more than you normally would while exercising, gives you no advantage. The extra weight you lose is body fluid and will be replaced with the next glass of water you drink. It is advisable to wear a pair of gym or running shoes or "sneakers".

Breathing During Exercise

Do not hold your breath while exercising. Breathe normally as much as possible. Remember, breathing involves the intake and distribution of oxygen, which feeds the working muscles.

Rest Periods

Once you start your exercise program, you should continue through to the end. Do not break off halfway through and then restart at the same place later on without going through the warm-up stage again.

The rest period required between strength training exercises may vary from person to person. This will depend mostly on your level of fitness and the program you have chosen. Rest between exercises by all means, but do not allow this to exceed two minutes. Most people manage with half-minute to one-minute rest periods.



Important Reminder

Make sure that there is minimum of 2 feet of clearance all around the rower.

1. While operating, make sure the unit is properly in position on a structurally sound, even surface.
2. Stand beside the seat, and step over the rower frame before seating yourself and placing your feet on the pedals.
3. Once properly seated on the rower, grasp the handles and start pedalling.

EXPLODED VIEW DIAGRAM

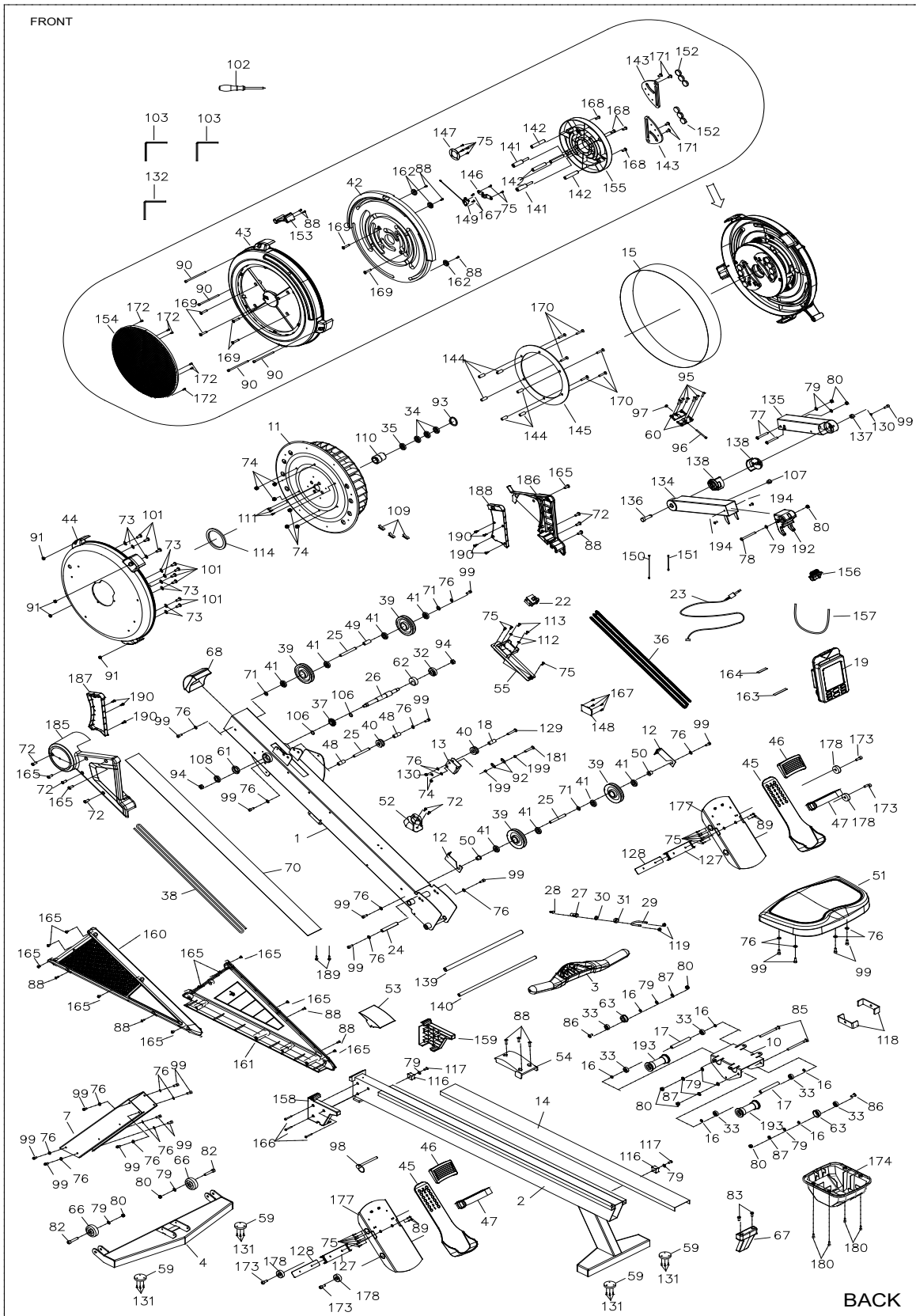

PARTS LIST

Key	Part Description	Q'ty
1	Main Frame	1
2	Rail Frame	1
3	Handlebar	1
4	Front Stabilizer	1
7	Front Support Leg	1
10	Seat Carriage	1
11	Fan	1
12	Bungee Cord Hook	2
13	Chain Bracket	1
14	Stainless Steel Rail	1
15	Perforated Steel Mesh	1
16	Spacer, 8.2x 12x3.2mm	6
17	Spacer, 8.2x 12x71.6mm	2
18	Spacer, 6.2x 10x15.5mm	1
19	Console Monitor	1
22	Generator	1
23	Sensor Cable	1
24	Shaft, M6x 12x80mm	1
25	Shaft, M6x 10x76.5mm	3
26	Fan Axle	1
27	Hook Connector	1
28	Chain Connector	1
29	U Bolt	1
30	Inner Spacer	1
31	Outer Collar	1
32	Bearing 6003RS	1
33	Bearing 608ZZ	6
34	Bearing 6201RS	3
35	One Way Bearing HF2016	1
36	Chain	1
37	Sprocket	1
38	Bungee Cord	1
39	Bungee Cord Pulley	4
40	Chain Roller	2
41	Bearing 6000ZZ	8
42	Damper	1
43	Left Fan Shroud	1
44	Right Fan Shroud	1
45	Foot Pedal	2
46	Foot Pedal Holder	2
47	Pedal Strap	2
48	Spacer, 10x 16x30.5mm	2
49	Pulley Spacer, 10x 16x26.5mm	1
50	Pulley Bushing	2
51	Seat	1

Key	Part Description	Q'ty
52	Handlebar Holder	1
53	Upper Joint Cover	1
54	Lower Joint Cover	1
55	Generator Base	1
57	Left Side Cover	1
58	Right Side Cover	1
59	Foot Cap	4
60	Steel Plate	2
61	Bushing 6001	1
62	Bushing 6003	1
63	Guide Roller	2
66	Transport Wheel	2
67	Rail End Cap	1
68	Main Frame Top Cap	1
70	Bottom Cover	1
71	Plastic Washer, 10.2x 14x1mm	3
72	Phillips Head Screw, M6x10mm	7
73	Lock Washer, Internal Tooth M6	9
74	Nylon Lock Nut, M6	8
75	Phillips Head Screw, ST4.2x10mm	21
76	Flat Washer, M6	22
77	Socket Head Cap Screw, M8x65mm	2
78	Button Head Cap Screw, M8x75mm	1
79	Flat Washer, M8	11
80	Nylon Lock Nut, M8	9
82	Socket Head Cap Screw, M8x45mm	2
83	Phillips Flat Head Screw, M6x16mm	2
85	Socket Head Cap Screw, M8x110mm	2
86	Button Head Cap Screw, M8x25mm	2
87	Lock Washer, M8	4
88	Phillips Head Screw, ST4.2x16mm	10
89	Phillips Flat Head Screw, M5x12mm	4
90	Socket Head Cap Screw, M5x92mm	4
91	Hex Nut, M5	4
92	Chain Hook	2
93	Elastic Ring	1
94	Nylon Lock Nut, M10	2
95	Phillips Head Screw, ST4.2x6mm	6
96	Phillips Head Screw, M4x45mm	1
97	Hex Nut, M4	1
98	Pull Pin	1
99	Socket Head Cap Screw, M6x16mm	21
100	Phillips Head Screw, M6x30mm (Full Thread)	1
101	Phillips Head Screw, M6x10mm	9
102	Screwdriver	1

Key	Part Description	Q'ty
103	Allen Wrench, 6mm	2
106	PU Spacer	2
107	Plug	1
108	Bearing, 6001RS	1
109	Balance Weight	3
110	Bearing Bushing	1
111	Socket Head Cap Screw, M4x12mm	3
112	Washer, 12x 3.5x1mm	2
113	Phillips Head Screw, ST3.5x12mm	2
114	Magnet	1
116	Stopper Bumper	2
117	Button Head Cap Screw, M8x20mm	2
118	Stopper Bracket	2
119	Thick Nylon Lock Nut, M16	2
126	Phillips Head Screw, ST4.2x10mm	8
127	Pedal Strap Protector	2
128	Pedal Strap Stopper Plate	2
129	Phillips Head Screw, M6x30mm (Half Thread)	1
130	Lock Washer, M6	2
131	Phillips Pan Head Self-drilling Screw, ST4.2X19mm	12
132	Allen Wrench, 5mm	1
134	Upper Console Monitor Post	1
135	Lower Console Monitor Post	1
136	Screw Shaft	1
137	Small Pulley Bushing	1
138	Rotation Sleeve	2
139	Pedal Shaft, 16mm	1
140	Pedal Shaft, 12mm	1
141	Pin, M6x77mm	2
142	Post, M6x63mm	4
143	Magnet Bracket	2
144	Stainless Steel Spacer, Φ 10x Φ 6x25mm	6
145	Aluminum Plate	1
146	VR Holder	1
147	Ring	1
148	Adaptor Board	1
149	VR	1
150	VR Wire	1
151	Generator Wire	1
152	Round Magnet	6
153	Indicator	1
154	Plastic Mesh	1
155	Magnet Bracket Base	1
156	Smartphone Holder	1
157	Bungee Cord of Smartphone Holder	1
158	Left Joint Cover	1

Key	Part Description	Q'ty
159	Right Joint Cover	1
160	Left Housing	1
161	Right Housing	1
162	Shoulder Washer	3
163	EVA Pad of Smartphone Holder 138*10*1.0t	1
164	EVA Pad of Smartphone Holder Base 46*11*1.0t	1
165	Phillips Pan Head Screw, M6X12mm	12
166	Phillips Pan Head Self-Tapping Screw, ST4.2X35mm	3
167	Phillips Pan Head Self-Tapping Screw, ST3.0X8mm	6
168	Button Head Cap Screw, M6X12mm	4
169	Hex Head Cap Screw, M6x20mm	6
170	Hex Head Cap Screw, M6x40mm	6
171	Phillips Head Screw, M6x16mm	4
172	Phillips Flat Head Self-Tapping Screw, ST4.2x16mm	6
173	Socket Head Cap Screw, M8X20mm	4
174	Seat Carriage Cover	1
177	Pedal Support Plate	2
178	Foot Pedal End Cap	4
180	Socket Head Cap Screw M5x16mm	4
181	Phillips Truss Head Screw M6x28mm	1
185	Left Side Cove	1
186	Right Side Cover	1
187	Left Inner Cover	1
188	Right Inner Cover	1
189	Phillips Pan Head Self-Tapping Locking Screw M4x16mm	2
190	Phillips Flat Head Self-Tapping Locking Screw ST4.2x10mm	7
192	Wide Console Holder	1
193	Seat Roller	2
194	Button Head Cap Screw M6x10mm	2
199	Spacer	2

MANUFACTURER'S LIMITED WARRANTY

Dyaco Canada Inc. warrants all its rowing parts for a period of time listed below from the date of retail sale, as determined by sale receipt. Dyaco Canada Inc.'s responsibilities include providing new or remanufactured parts at Dyaco Canada Inc.'s option and technical support to our independent dealers and servicing organizations. In the absence of a dealer or service organization, these warranties will be administered by Dyaco Canada Inc. directly to a consumer. The warranty period applies to the following components:

Frame	5 years
Parts	2 years
Labour	1 year

This warranty applies only to products in ordinary household use, and the consumer is responsible for the items listed below: The warranty registration must be completed. Visit us at www.dyaco.ca and complete the registration within 10 days of the original purchase.

1. Proper use of the rower in accordance with the instructions provided in this manual.
2. Proper installation in accordance with instructions provided with the rower.
3. Expenses for making the rower accessible for servicing, including any item that was not part of the rower at the time it was shipped from the factory.
4. Damages to the rower finish during shipping, installation or following installation.
5. Routine maintenance of this unit as specified in this manual.

EXCLUSIONS

This warranty does not cover the following:

1. CONSEQUENTIAL, COLLATERAL, OR INCIDENTAL DAMAGES SUCH AS PROPERTY DAMAGE AND INCIDENTAL EXPENSES RESULTING FROM ANY BREACH OF THIS WRITTEN OR ANY IMPLIED WARRANTY.
Note: Some areas do not allow the exclusion or limitation of incidental or consequential damages, so this limitation or exclusion may not apply to you.
2. Service call reimbursement to the consumer. Service call reimbursement to the dealer that does not involve malfunction or defects in workmanship or material, for units that are beyond the warranty period, for units that are beyond the service call reimbursement period, for rower not requiring component replacement, or rower not in ordinary household use.
3. Damages caused by services performed by persons other than authorized Dyaco Canada Inc. service companies; use of parts other than original Dyaco Canada Inc. parts; or external causes such as corrosion, discoloration of paint or plastic, alterations, modifications, abuse, misuse, accident, improper maintenance, inadequate power supply, or acts of God.
4. Products with original serial numbers that have been removed or altered.
5. Products that have been: sold, transferred, bartered, or given to a third party.
6. Products that do not have a warranty registration card on file at Dyaco Canada Inc. Dyaco Canada Inc. reserves the right to request proof of purchase if no warranty record exists for the product.
7. THIS WARRANTY IS EXPRESSLY IN LIEU OF ALL OTHER WARRANTIES EXPRESSED OR IMPLIED, INCLUDING THE WARRANTIES OF MERCHANTABILITY AND/OR FITNESS FOR A PARTICULAR PURPOSE.
8. Product use in any environment other than a residential setting.
9. Warranties outside of North America may vary. Please contact your local dealer or Dyaco Canada Inc. for details.

SERVICE

The sales receipt establishes the labour warranty period should service be required. If service is performed, it is in your best interest to obtain and keep all receipts. This written warranty gives you specific legal rights.

Service under this warranty must be obtained by following these steps, in order:

1. Contact your selling authorized SOLE dealer or Dyaco Canada Inc.
2. If you have any questions about your new product or questions about the warranty, contact Dyaco Canada Inc. at 1-888-707-1880.
3. If no local service is available, Dyaco Canada Inc. will repair or replace the parts, at Dyaco Canada Inc.'s option, within the warranty period at no charge for parts. All transportation costs, both to our factory and upon return to the owner, are the responsibility of the owner.
4. The owner is responsible for adequate packaging upon return to Dyaco Canada Inc. Dyaco Canada Inc. is not responsible for damages that occur during shipping. Make all freight damage claims with the appropriate freight carrier. DO NOT SHIP ANY UNIT TO OUR FACTORY WITHOUT A RETURN AUTHORIZATION NUMBER. All units arriving without a return authorization number will be refused.
5. For any further information, or to contact our service department by mail, send your correspondence to:

Dyaco Canada Inc.
5955 Don Murie Street
Niagara Falls, ON
L2G 0A9

Product features or specifications as described or illustrated are subject to change without notice.
All warranties are made by Dyaco Canada Inc.

dyaco

Please visit us online for information about our other brands and products manufactured and distributed by Dyaco Canada Inc.

SPIRIT

spiritfitness.ca

SOLE
FITNESS

solefitness.ca

X TERRA
FITNESS

xterrafitness.ca

EVERLAST

dyaco.ca/everlast.html

Cikada

cikada.ca

TRAINOR
SPORTS

trainorsports.ca

For more information, please contact Dyaco Canada Inc.

T: 1-888-707-1880 | 5955 Don Murie St., Niagara Falls, Ontario L2G 0A9 | sales@dyaco.ca

SOLE
FITNESS